

Free of maintenance stop valve with bellows seal - metallic sealing

ARI-FABA®-Plus -

Straight through with flanges

- DIN DVGW-Type approval
- TA - Luft TÜV-Test-No. 973-10183778
- TRB 801 Annex II No. 45 (except EN-JL1040)

Grey cast iron
SG iron
Cast steel
Forged steel
Stainless steel

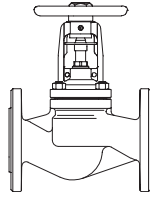

Fig. 046

Page 2-4

ARI-FABA®-Plus -

Straight through with butt weld ends

- DIN DVGW-Type approval
- TA - Luft TÜV-Test-No. 973-10183778
- TRB 801 Annex II No. 45

Forged steel

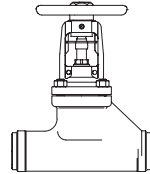

Fig. 040

Page 5

ARI-FABA®-Plus -

Straight through with butt weld ends

- DIN DVGW-Type approval
- TA - Luft TÜV-Test-No. 973-10183778
- TRB 801 Annex II No. 45

Cast steel

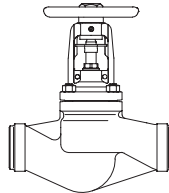

Fig. 040

Page 6

ARI-FABA®-Plus -

Y-pattern with flanges

- TA - Luft TÜV-Test-No. 973-10183778
- TRB 801 Annex II No. 45

Stainless steel

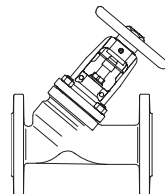

Fig. 069

Page 7

ARI-FABA®-Plus -

Y-pattern with butt weld ends

- DIN DVGW-Type approval
- TA - Luft TÜV-Test-No. 973-10183778
- TRB 801 Annex II No. 45

Cast steel
Stainless steel

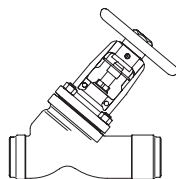

Fig. 066

Page 8+9

ARI-FABA®-Plus -

Angle pattern with flanges

- DIN DVGW-Type approval
- TA - Luft TÜV-Test-No. 973-10183778
- TRB 801 Annex II No. 45 (except EN-JL1040)

Grey cast iron
SG iron
Cast steel

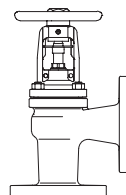

Fig. 047

Page 10

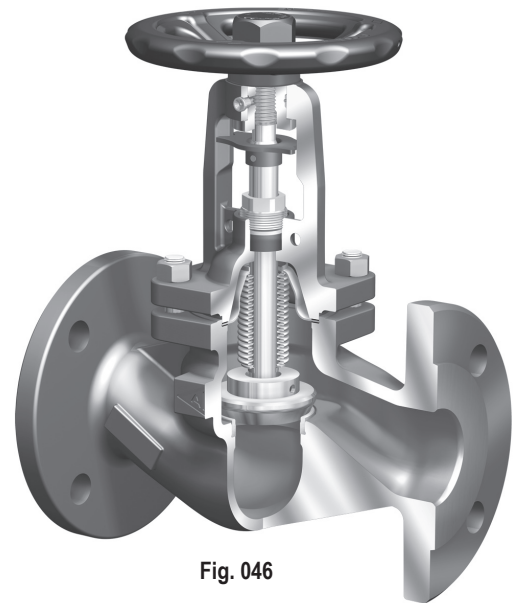

Fig. 046

For ANSI versions refer to data sheet „ARI-FABA®-Plus/-Supra ANSI“

Features:

- Double wall bellows seal as standard
- Plug with marginal seat
- Stem with fine thread
- Flat lubricating nipple
- Locking device, countersunk
- Cast iron variations with nodular iron bonnet as standard
- Heat dissipating bonnet
- Bonnet optimised for accessories
- Secondary sealing: gland packing
- Position indicator as standard
- Non-rising handwheel
- Non-rotation lock for each nominal diameter
- External stem thread
- Stem with roll hardened thread

Stop valve - straight through with flanges and bellows seal (Grey cast iron, SG iron, Cast steel)

Figure-No.	Nominal pressure	Material	Nominal diameter
12.046	PN16	EN-JL1040	DN15-300
22.046	PN16	EN-JS1049	DN15-350
	Test: • DIN DVGW-Reg. DG-4313AO 0772		
23.046	PN25	EN-JS1049	DN15-150
34.046	PN25	1.0619+N	DN200-400
	Test: • DIN DVGW-Reg. DG-4314AO 0777		
35.046	PN40	1.0619+N	DN15-250
	Test: • DIN DVGW-Reg. DG-4314AO 0778		
Test: • TA - Luft TÜV-Test-No. 973-10183778			
Plug with marginal seat standard			
At high differential pressures a balancing plug is necessary! (refer to page 12)			

Selection of possible applications

Industry, Powerstations, Flue gas purification plant, processing technology, gas supply, vapour facilities, recycling facilities, vacuum facilities, hot water, heating technology, district heating, thermal oil applications, general plant manufacturing, etc.

(other applications on request)

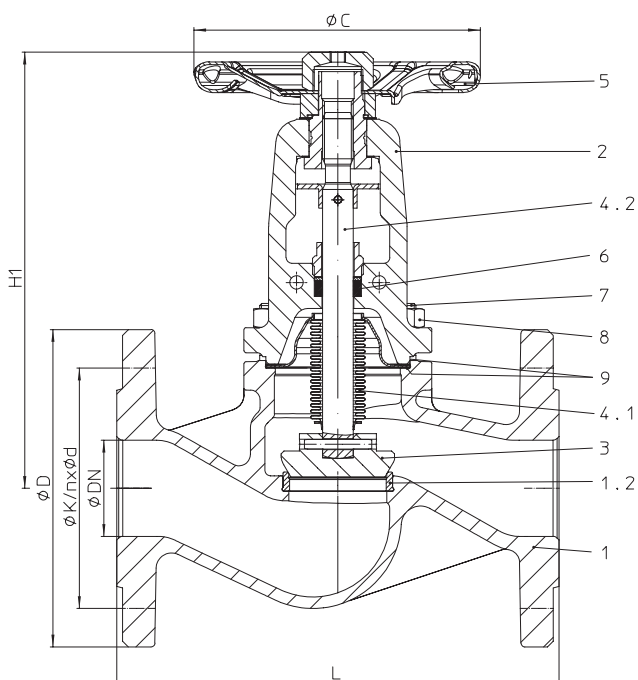
Selection of possible flow media

Steam, gases, hot water, thermal fluids, hot oil, process water, vacuum facilities, ammonia etc.

(other flow media on request)

Parts

Pos.	Description	Fig. 12.046	Fig. 22. / 23.046	Fig. 34. / 35.046
1	Body	EN-JL1040, EN-GJL-250	EN-JS1049, EN-GJS-400-18U-LT	GP240GH+N, 1.0619+N
1.2	Seat ring	X20Cr13+QT, 1.4021+QT		≤DN50: X20Cr13+QT, 1.4021+QT / ≥DN65: G19 9 NbSi, 1.4551
2	Bonnet	EN-JS1049, EN-GJS-400-18U-LT		GP240GH+N, 1.0619+N
3	Plug *	≤ DN200: X20Cr13+QT, 1.4021+QT (hardened) / ≥ DN250: P265GH, 1.0425 / G19 9 Nb Si, 1.4551		
4.1	Bellows seal	X6CrNiMoTi17 12 2, 1.4571		
4.2	Stem	X20Cr13+QT, 1.4021+QT		
5	Handwheel *	≤DN125: St (cataphoretic coating) / ≥DN150: EN-JL1040, EN-GJL-250 (epoxy-coating)		
6	Packing ring	Pure graphite		
7	Hexagon bolt	5.6	--	--
7	Stud	--	25CrMo4, 1.7218	--
8	Hexagon nut	--	C35E, 1.1181	--
9	Gasket *	Pure graphite (CrNi laminated with graphite)		

* Spare part

Information / restriction of technical rules need to be observed!

Operating instructions can be ordered by phone +49 (0)5207 / 994-0 or fax +49 (0)5207 / 994-158 or -159.

ARI-Valves of EN-JL1040 are not allowed to be operated in systems acc. to TRD 110.

A production allowance acc. to TRB 801 No. 45 exists (acc. to TRB 801 No. 45 EN-JL1040 is not allowed.)

The engineer, designing a system or a plant, is responsible for the selection of the correct valve.

Dimensions

	DN	15	20	25	32	40	50	65	80	100	125	150	200	250	300	350	400
L	(mm)	130	150	160	180	200	230	290	310	350	400	480	600	730	850	980	1100
H1	(mm)	205	205	210	210	225	230	245	265	365	395	430	550	720	775	975	1015
ØC (PN16)	(mm)	125	125	125	125	150	150	175	175	225	300	400	520	520	520	640	640
ØC (PN25)	(mm)	125	125	125	125	150	150	175	175	300	300	400	520	520	520	640	640
ØC (PN40)	(mm)	125	125	125	125	150	150	175	225	300	300	400	520	520	--	--	--
Travel	(mm)	6	6	8	8	13	13	16	20	25	32	40	50	70	80	90	100
Kvs-value	(m³/h)	5,3	7,2	12	16	28,5	43	75	105	170	270	405	675	1090	1460	2010	2640
Zeta-value	--	2,9	4,9	4,3	6,5	5	5,4	5,1	5,9	5,5	5,3	4,9	5,6	5,2	6,1	5,9	5,9

Zeta-value ... range of tolerance for Kvs-values acc. to VDI/VDE 2173

Standard-flange dimensions refer to page 14

Face-to-face dimension FTF Grundreihe 1 acc. to DIN EN 558

Weights

Figure-No.	DN	15	20	25	32	40	50	65	80	100	125	150	200	250	300	350	400
12. / 22. / 23.046	(kg)	3,7	4,5	5,6	6,9	8,9	11	15,3	21,1	32,4	51,6	74	147	247	404	524	--
34.046	(kg)	--	--	--	--	--	--	--	--	--	--	--	168	268	395	629	865
35.046	(kg)	4,1	5,1	6,2	7,3	10,6	12,6	19,1	26,1	35	60,3	88	225	310	--	--	--

Stop valve - straight through with flanges and bellows seal (Stainless steel)

Figure-No.	Nominal pressure	Material	Nominal diameter
52.046	PN16	1.4408	DN15-250
62.046	PN16	1.4408 Body / 1.0619+N Cover	DN15-250
54.046	PN25	1.4408	DN200-250
64.046	PN25	1.4408 Body / 1.0619+N Cover	DN200-250
55.046	PN40	1.4408	DN15-150
65.046	PN40	1.4408 Body / 1.0619+N Cover	DN15-150

Test: • TA - Luft TÜV-Test-No. 973-10183778

Plug with marginal seat standard

At high differential pressures a balancing plug is necessary! (refer to page 12)

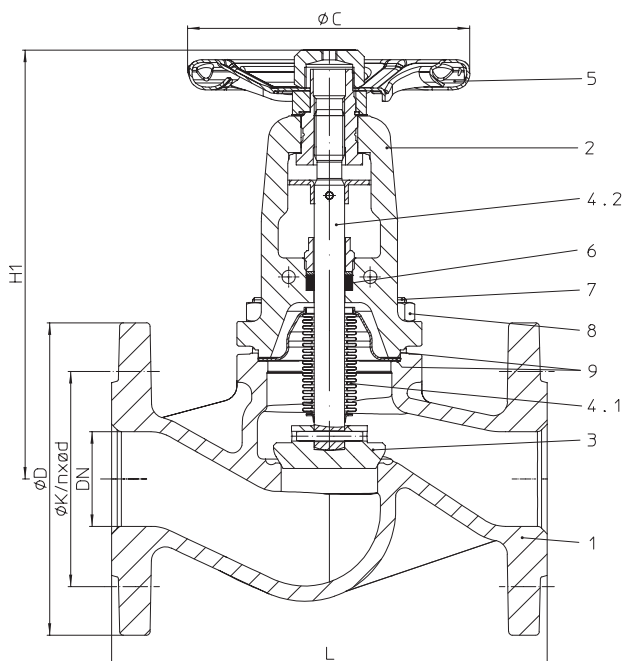
Selection of possible applications

 Recycling facilities, chemical industry, hospital technology, process water installations, installations with aggressive media
 (other applications on request)

Selection of possible flow media

 Process water, aggressive media, etc.
 (other flow media on request)

Parts

Pos.	Description	Fig. 52. / 54. / 55.046	Fig. 62. / 64. / 65.046
1	Body	GX5CrNiMo19-11-2, 1.4408	
2	Bonnet	GX5CrNiMo19-11-2, 1.4408	GP240GH+N, 1.0619+N
3	Plug *	X6CrNiMoTi17 12 2, 1.4571	
4.1	Bellows seal	X6CrNiMoTi17 12 2, 1.4571	
4.2	Stem	X6CrNiMoTi17 12 2, 1.4571	
5	Handwheel *	≤DN125: St (cataphoretic coating) / ≥DN150: EN-JL1040, EN-GJL-250 (epoxy-coating)	
6	Packing ring	Pure graphite	
7	Hexagon bolt	--	
7	Stud	A4-70	25CrMo4, 1.7218
8	Hexagon nut	A4	C35E, 1.1181
9	Gasket *	Pure graphite (CrNi laminated with graphite)	

* Spare part

Information / restriction of technical rules need to be observed!

Operating instructions can be ordered by phone +49 (0)5207 / 994-0 or fax +49 (0)5207 / 994-158 or -159.

A production allowance acc. to TRB 801 No. 45 exists

The engineer, designing a system or a plant, is responsible for the selection of the correct valve.

Dimensions

	DN	15	20	25	32	40	50	65	80	100	125	150	200	250
L	(mm)	130	150	160	180	200	230	290	310	350	400	480	600	730
H1	(mm)	200	200	210	210	225	230	245	265	365	395	430	550	720
ØC (PN16)	(mm)	125	125	125	125	150	150	175	175	225	300	400	520	520
ØC (PN25)	(mm)	125	125	125	125	150	150	175	175	300	300	400	520	520
ØC (PN40)	(mm)	125	125	125	125	150	150	175	225	300	300	400	520	520
Travel	(mm)	6	6	8	8	13	13	16	20	25	32	40	50	70
Kvs-value	(m³/h)	5,3	7,2	12	16	28,5	43	75	105	170	270	405	675	1090
Zeta-value	--	2,9	4,9	4,3	6,5	5	5,4	5,1	5,9	5,5	5,3	4,9	5,6	5,2

Zeta-value ... range of tolerance for Kvs-values acc. to VDI/VDE 2173

Standard-flange dimensions refer to page 14

Face-to-face dimension FTF Grundreihe 1 acc. to DIN EN 558

Weights

Figure-No.	DN	15	20	25	32	40	50	65	80	100	125	150	200	250
52. / 54. / 62. / 55. / 64. / 65.046	(kg)	4,3	4,8	6,3	7,3	10,3	12,6	19	25	33	53	71	187	272

Stop valve - straight through with flanges and bellows seal (Forged steel)

DN40-50

Figure-No.	Nominal pressure	Material	Nominal diameter
45.046	PN40	1.0460	DN15-50
	DN >50 refer to Fig. 35.046 (1.0619+N)		
Test: • TA - Luft TÜV-Test-No. 973-10183778			
Plug with marginal seat standard			

Selection of possible applications

Industry, Powerstations, Flue gas purification plant, processing technology, gas supply, vapour facilities, recycling facilities, vacuum facilities, hot water, heating technology, district heating, thermal oil applications, general plant manufacturing, etc. (other applications on request)

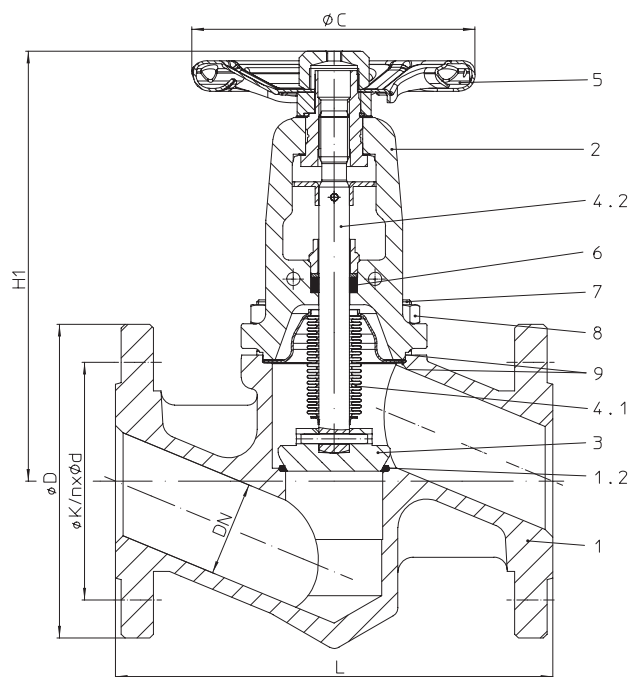
Selection of possible flow media

Steam, gases, hot water, thermal fluids, hot oil, process water, vacuum facilities, ammonia etc. (other flow media on request)

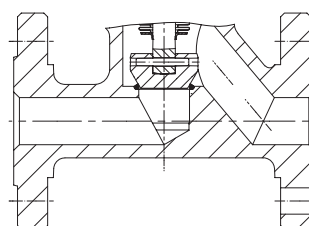
DN15-32
Parts

Pos.	Description	Fig. 45.046
1	Body	P250 GH, 1.0460
1.2	Seat	G19 9 NbSi, 1.4551
2	Bonnet	GP240GH+N, 1.0619+N
3	Plug *	X20Cr13+QT, 1.4021+QT (hardened)
4.1	Bellows seal	X6CrNiMoTi17 12 2, 1.4571
4.2	Stem	X20Cr13+QT, 1.4021+QT
5	Handwheel *	Fe P01, 1.0330 (cataphoretic coating)
6	Packing ring	Pure graphite
7	Stud	25CrMo4, 1.7218
8	Hexagon nut	C35E, 1.1181
9	Gasket *	Pure graphite (CrNi laminated with graphite)

* Spare part

Information / restriction of technical rules need to be observed!

Operating instructions can be ordered by phone +49 (0)5207 / 994-0 or fax +49 (0)5207 / 994-158 or -159.

A production allowance acc. to TRB 801 No. 45 exists.

The engineer, designing a system or a plant, is responsible for the selection of the correct valve.

Dimensions

	DN	15	20	25	32	40	50
L	(mm)	130	150	160	180	200	230
H1	(mm)	215	215	225	230	230	230
ØC (PN40)	(mm)	125	125	125	125	150	150
Travel	(mm)	6	6	8	8	13	13
Kvs-value	(m³/h)	3,6	6,3	10	13	24	36
Zeta-value	--	6,2	6,4	6,2	9,9	7,1	7,7

Zeta-value ... range of tolerance for Kvs-values acc. to VDI/VDE 2173 Standard-flange dimensions refer to page 14

Face-to-face dimension FTF Grundreihe 1 acc. to DIN EN 558

Weights

Figure-No.	DN	15	20	25	32	40	50
45.046	(kg)	3,8	4,8	5,5	7	10	12

Stop valve - straight through with butt weld ends and bellows seal (Forged steel)

Figure-No.	Nominal pressure	Material	Nominal diameter
45.040	PN40	1.0460	DN15-50
	DN >50 refer to Fig. 35.040 (1.0619+N)		
Butt weld ends according to DIN EN 12627 - 4 (refer to page 11)			
Test: • TA - Luft TÜV-Test-No. 973-10183778			
Plug with marginal seat standard			

Selection of possible applications

Industry, Powerstations, Flue gas purification plant, processing technology, gas supply, vapour facilities, recycling facilities, vacuum facilities, hot water, heating technology, district heating, thermal oil applications, general plant manufacturing, etc.
 (other applications on request)

Selection of possible flow media

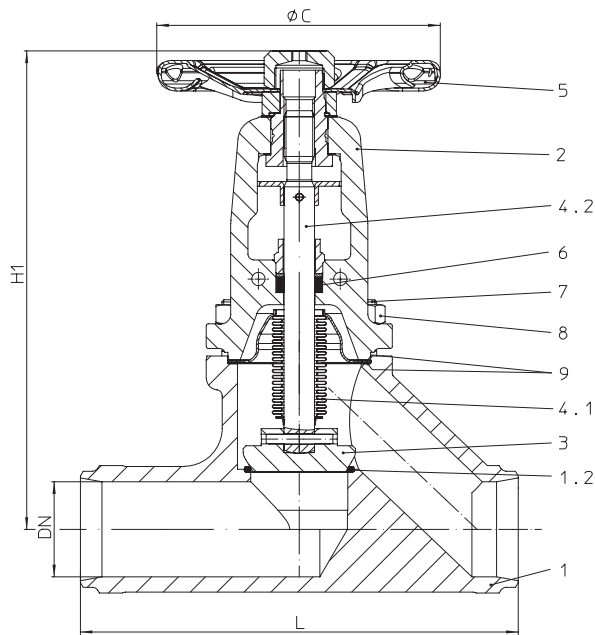
Steam, gases, hot water, thermal fluids, hot oil, process water, vacuum facilities, ammonia etc.
 (other flow media on request)

Parts

Pos.	Description	Fig. 45.040
1	Body	P250 GH, 1.0460
1.2	Seat	G19 9 NbSi, 1.4551
2	Bonnet	GP240GH+N, 1.0619+N
3	Plug *	X20Cr13+QT, 1.4021+QT (hardened)
4.1	Bellows seal	X6CrNiMoTi17 12 2, 1.4571
4.2	Stem	X20Cr13+QT, 1.4021+QT
5	Handwheel *	Fe P01, 1.0330 (cataphoretic coating)
6	Packing ring	Pure graphite
7	Stud	25CrMo4, 1.7218
8	Hexagon nut	C35E, 1.1181
9	Gasket *	Pure graphite (CrNi laminated with graphite)

* Spare part

Information / restriction of technical rules need to be observed!

Operating instructions can be ordered by phone +49 (0)5207 / 994-0 or fax +49 (0)5207 / 994-158 or -159.

A production allowance acc. to TRB 801 No. 45 exists

The engineer, designing a system or a plant, is responsible for the selection of the correct valve.

Dimensions

	DN	15	20	25	32	40	50
L	(mm)	130	150	160	180	200	230
H1	(mm)	215	215	225	230	250	255
ØC (PN40)	(mm)	125	125	125	125	150	150
Travel	(mm)	6	6	8	8	13	13
Kvs-value	(m³/h)	3,6	3,6	10	13	21	32
Zeta-value	--	6,2	6,4	6,2	9,9	9,3	9,7

Zeta-value ... range of tolerance for Kvs-values acc. to VDI/VDE 2173

Face-to-face dimension ETE series 1 according to DIN EN 12982

Weights

Figure-No.	DN	15	20	25	32	40	50
45.040	(kg)	2,6	2,8	3,8	4,2	5,8	8,2

Stop valve - straight through with butt weld ends and bellows seal (Cast steel)

Figure-No.	Nominal pressure	Material	Nominal diameter
34.040	PN25	1.0619+N	DN200-300
35.040	PN40	1.0619+N	DN65-250
Butt weld ends according to DIN EN 12627 - 4 (refer to page 11) alternative: DN 65-200 with shoed ends of P235GH			
Test: • TA - Luft TÜV-Test-No. 973-10183778 • DIN DVGW-Reg. DG-4314AO 0777/0778			
DN65-150: Plug with marginal seat standard			
At high differential pressures a balancing plug is necessary! (refer to page 12)			

Selection of possible applications

Industry, Powerstations, Flue gas purification plant, processing technology, gas supply, vapour facilities, recycling facilities, vacuum facilities, hot water, heating technology, district heating, thermal oil applications, general plant manufacturing, etc.
(other applications on request)

Selection of possible flow media

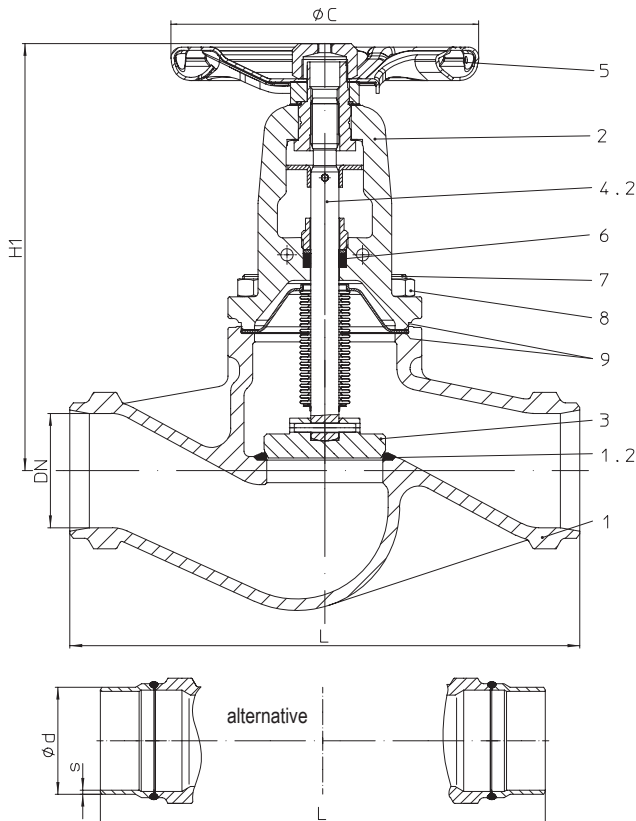
Steam, gases, hot water, thermal fluids, hot oil, process water, vacuum facilities, ammonia etc.
(other flow media on request)

Parts

Pos.	Description	Fig. 34.040 / 35.040
1	Body	GP240GH+N, 1.0619+N
1.2	Seat	G19 9 NbSi, 1.4551
2	Bonnet	GP240GH+N, 1.0619+N
3	Plug *	≤DN200: X20Cr13+QT, 1.4021+QT (hardened) / ≥DN250: P265GH, 1.0425 / G19 9 Nb Si, 1.4551
4.1	Bellows seal	X6CrNiMoTi17 12 2, 1.4571
4.2	Stem	X20Cr13+QT, 1.4021+QT
5	Handwheel *	≤DN125: St (cataphoretic coating) / >DN125: EN-JL1040, EN-GJL-250 (epoxy-coating)
6	Packing ring	Pure graphite
7	Stud	25CrMo4, 1.7218
8	Hexagon nut	C35E, 1.1181
9	Gasket *	Pure graphite (CrNi laminated with graphite)

* Spare part

Information / restriction of technical rules need to be observed!

Operating instructions can be ordered by phone +49 (0)5207 / 994-0 or fax +49 (0)5207 / 994-158 or -159.

A production allowance acc. to TRB 801 No. 45 exists

The engineer, designing a system or a plant, is responsible for the selection of the correct valve.

Dimensions

	DN	65	80	100	125	150	200	250	300
L	(mm)	290	310	350	400	480	600	730	850
H1	(mm)	245	265	365	395	430	550	720	775
ØC (PN25)	(mm)	--	--	--	--	--	520	520	520
ØC (PN40)	(mm)	175	225	300	300	400	520	520	--
Travel	(mm)	16	20	25	32	40	50	70	80
Kvs-value	(m³/h)	75	105	170	270	405	675	1090	1460
Zeta-value	--	5,1	5,9	5,5	5,3	4,9	5,6	5,2	6,1

Zeta-value ... range of tolerance for Kvs-values acc. to VDI/VDE 2173

Face-to-face dimension ETE series 1 according to DIN EN 12982

Weights

Figure-No.	DN	65	80	100	125	150	200	250	300
34.040	(kg)	--	--	--	--	--	160	242	370
35.040	(kg)	12	16,8	23,6	40	56	166	251	--

Stop valve - Y-pattern with flanges and bellows seal (Stainless steel)

Figure-No.	Nominal pressure	Material	Nominal diameter
52.069	PN16	1.4408	DN15-200
62.069	PN16	1.4408 Body / 1.0619+N Cover	DN15-200
54.069	PN25	1.4408	DN200
64.069	PN25	1.4408 Body / 1.0619+N Cover	DN200
55.069	PN40	1.4408	DN15-150
65.069	PN40	1.4408 Body / 1.0619+N Cover	DN15-150

Test: • TA - Luft TÜV-Test-No. 973-10183778

Plug with marginal seat standard

At high differential pressures a balancing plug is necessary! (refer to page 12)

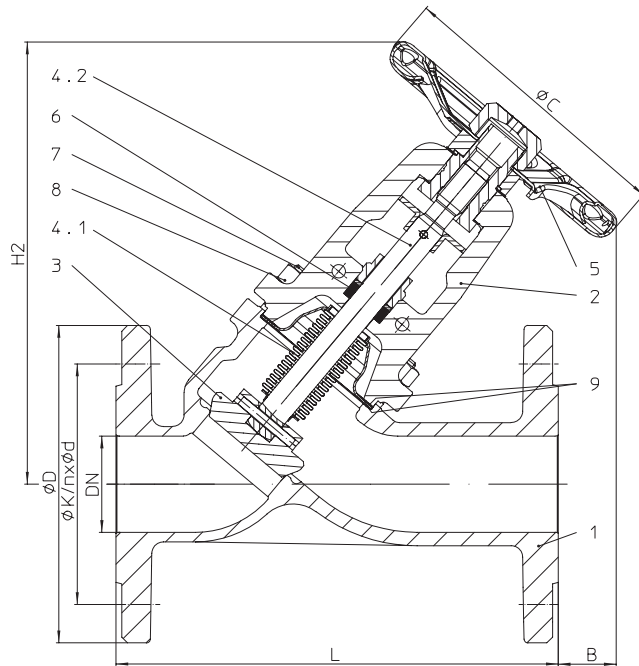
Selection of possible applications

Recycling facilities, chemical industry, hospital technology, process water installations, installations with aggressive media (other applications on request)

Selection of possible flow media

Process water, aggressive media, etc. (other flow media on request)

Parts

Pos.	Description	Fig. 52.069 / Fig. 54.069 / Fig. 55.069	Fig. 62.069 / Fig. 64.069 / Fig. 65.069
1	Body	GX5CrNiMo19-11-2, 1.4408	
2	Bonnet	GX5CrNiMo19-11-2, 1.4408	GP240GH+N, 1.0619+N
3	Plug *	X6CrNiMoTi17 12 2, 1.4571	
4.1	Bellows seal	X6CrNiMoTi17 12 2, 1.4571	
4.2	Stem	X6CrNiMoTi17 12 2, 1.4571	
5	Handwheel *	≤DN125: St (cathaphoretic coating) / ≥DN150: EN-JL1040, EN-GJL-250 (epoxy-coating)	
6	Packing ring	Pure graphite	
7	Stud	A4-70	25CrMo4, 1.7218
8	Hexagon nut	A4	C35E, 1.1181
9	Gasket *	Pure graphite (CrNi laminated with graphite)	

* Spare part

Information / restriction of technical rules need to be observed!

Operating instructions can be ordered by phone +49 (0)5207 / 994-0 or fax +49 (0)5207 / 994-158 or -159.

A production allowance acc. to TRB 801 No. 45 exists

The engineer, designing a system or a plant, is responsible for the selection of the correct valve.

Dimensions

	DN	15	20	25	32	40	50	65	80	100	125	150	200
L	(mm)	130	150	160	180	200	230	290	310	350	400	480	600
H2	(mm)	195	195	205	205	235	235	265	295	380	415	480	615
ØC (PN16)	(mm)	125	125	125	125	150	150	175	175	225	300	400	520
ØC (PN25)	(mm)	125	125	125	125	150	150	175	175	300	300	400	520
ØC (PN40)	(mm)	125	125	125	125	150	150	175	225	300	300	400	520
B	(mm)	95	70	70	55	65	35	15	50	120	100	90	140
Travel	(mm)	6	6	8	8	13	13	16	20	25	32	40	50
Kvs-value	(m³/h)	6,4	9,5	14,5	19,5	36	54	92	127	205	324	485	810
Zeta-value	--	2	2,8	3	4,4	3,2	3,4	3,4	4,1	3,8	3,7	3,4	3,9

Zeta-value ... range of tolerance for Kvs-values acc. to VDI/VDE 2173

Standard-flange dimensions refer to page 14

Face-to-face dimension FTF Grundreihe 1 acc. to DIN EN 558

Weights

Figure-No.	DN	15	20	25	32	40	50	65	80	100	125	150	200
52. / 54. / 62.069	(kg)	4	4,5	5,4	6,5	8,5	11,7	16	21,7	31,1	43,5	62	180
55. / 64. / 65.069	(kg)	4	4,5	5,4	6,5	8,5	11,7	16	21,7	31,1	43,5	62	186

Stop valve - Y-pattern with butt weld ends and bellows seal (Cast steel)

Figure-No.	Nominal pressure	Material	Nominal diameter
34.066	PN25	1.0619+N	DN200-300
	Test: • DIN DVGW-Reg. DG-4314AO 0775		
35.066	PN40	1.0619+N	DN15-250
	Test: • DIN DVGW-Reg. DG-4314AO 0776		
Butt weld ends according to DIN EN 12627 - 4 (refer to page 11)			
Test: • TA - Luft TÜV-Test-No. 973-10183778			
Plug with marginal seat standard			
At high differential pressures a balancing plug is necessary! (refer to page 12)			

Selection of possible applications

Industry, Powerstations, Flue gas purification plant, processing technology, gas supply, vapour facilities, recycling facilities, vacuum facilities, hot water, heating technology, district heating, thermal oil applications, general plant manufacturing, etc.

(other applications on request)

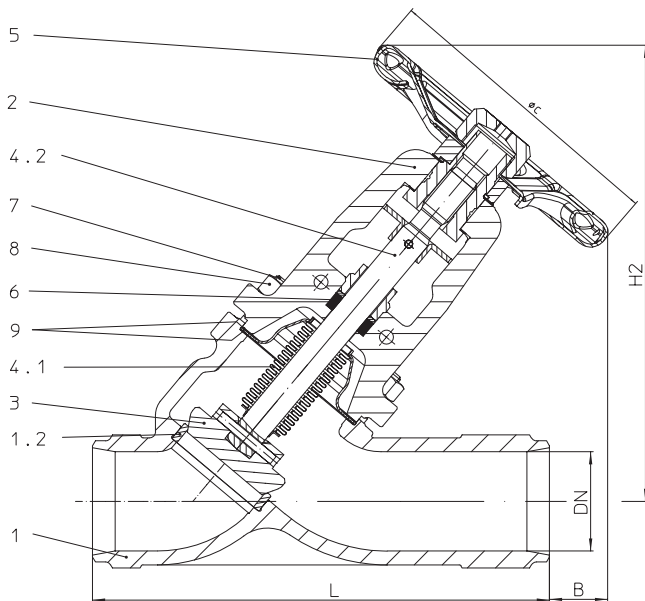
Selection of possible flow media

Steam, gases, hot water, thermal fluids, hot oil, process water, vacuum facilities, ammonia etc. (other flow media on request)

Parts

Pos.	Description	Fig. 34./35.066
1	Body	GP240GH+N, 1.0619+N
1.2	Seat ring	≤DN50: X20Cr13+QT, 1.4021+QT / ≥DN65: G19 9 NbSi, 1.4551
2	Bonnet	GP240GH+N, 1.0619+N
3	Plug *	≤DN200: X20Cr13+QT, 1.4021+QT (hardened) / ≥DN250: P265GH, 1.0425 / G19 9 Nb Si, 1.4551
4.1	Bellows seal	X6CrNiMoTi17 12 2, 1.4571
4.2	Stem	X20Cr13+QT, 1.4021+QT
5	Handwheel *	≤DN125: St (cataphoretic coating) / >DN125: EN-JL 1040, EN-GJL-250 (epoxy-coating)
6	Packing ring	Pure graphite
7	Stud	25CrMo4, 1.7218
8	Hexagon nut	C35E, 1.1181
9	Gasket *	Pure graphite (CrNi laminated with graphite)

* Spare part

Information / restriction of technical rules need to be observed!

Operating instructions can be ordered by phone +49 (0)5207 / 994-0 or fax +49 (0)5207 / 994-158 or -159.

A production allowance acc. to TRB 801 No. 45 exists

The engineer, designing a system or a plant, is responsible for the selection of the correct valve.

Dimensions

	DN	15	20	25	32	40	50	65	80	100	125	150	200	250	300
L	(mm)	130	150	160	180	200	230	290	310	350	400	480	600	730	850
H2	(mm)	195	195	205	205	235	235	265	295	380	415	480	615	740	795
B	(mm)	85	65	65	50	60	35	10	45	90	60	50	110	100	45
ØC (PN25)	(mm)	--	--	--	--	--	--	--	--	--	--	--	520	520	520
ØC (PN40)	(mm)	125	125	125	125	150	150	175	225	300	300	400	520	520	--
Travel	(mm)	6	6	8	8	13	13	16	20	25	32	40	50	70	80
Kvs-value	(m³/h)	6,4	9,5	14,5	19,5	36	54	92	127	205	324	485	810	1310	1752
Zeta-value	--	2	2,8	3	4,4	3,2	3,4	3,4	4,1	3,8	3,7	3,4	3,9	3,6	4,2

Zeta-value ... range of tolerance for Kvs-values acc. to VDI/VDE 2173

Face-to-face dimension ETE series 1 according to DIN EN 12982

Weights

Figure-No.	DN	15	20	25	32	40	50	65	80	100	125	150	200	250	300
34.066	(kg)	--	--	--	--	--	--	--	--	--	--	--	138	230	317
35.066	(kg)	2,8	3	3,4	3,6	4,5	7,3	9	11,4	30	42	62	144	239	--

Stop valve - Y-pattern with butt weld ends and bellows seal (Stainless steel)

Figure-No.	Nominal pressure	Material	Nominal diameter
54.066	PN25	1.4581	DN200
55.066	PN40	1.4581	DN15-150
Butt weld ends according to DIN EN 12627 - 4 (refer to page 11)			
Test: • TA - Luft TÜV-Test-No. 973-10183778			
Plug with marginal seat standard			
At high differential pressures a balancing plug is necessary! (refer to page 12)			

Selection of possible applications

Stainless steel: Recycling facilities, chemical industry, hospital technology, process water installations, installations with aggressive media

(other applications on request)

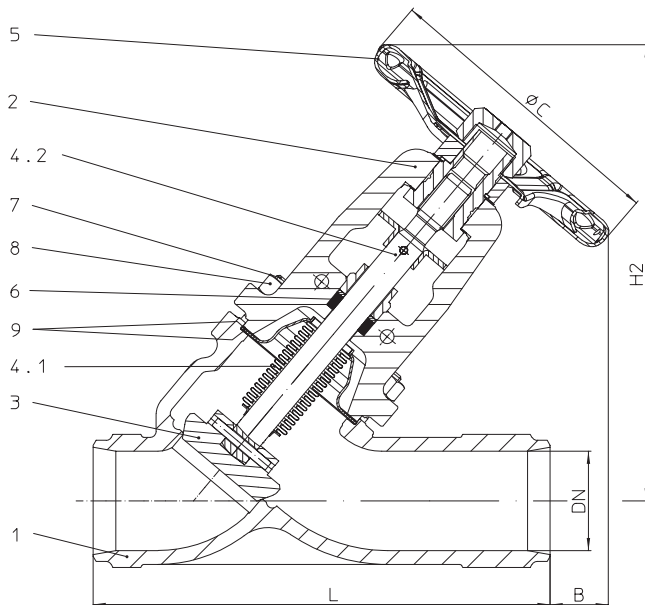
Selection of possible flow media

Process water, aggressive media, etc.

(other flow media on request)

Parts

Pos.	Description	Fig. 54./55.066
1	Body	GX5CrNiMoN19-11-2, 1.4581
2	Bonnet	GX5CrNiMo19-11-2, 1.4408
3	Plug *	X6CrNiMoTi17 12 2, 1.4571
4.1	Bellows seal	X6CrNiMoTi17 12 2, 1.4571
4.2	Stem	X6CrNiMoTi17 12 2, 1.4571
5	Handwheel *	≤DN125: St (cataphoretic coating) / >DN125: EN-JL1040, EN-GJL-250 (epoxy-coating)
6	Packing ring	Pure graphite
7	Stud	A2-70
8	Hexagon nut	A2
9	Gasket *	Pure graphite (CrNi laminated with graphite)

* Spare part

Information / restriction of technical rules need to be observed!

Operating instructions can be ordered by phone +49 (0)5207 / 994-0 or fax +49 (0)5207 / 994-158 or -159.

A production allowance acc. to TRB 801 No. 45 exists

The engineer, designing a system or a plant, is responsible for the selection of the correct valve.

Dimensions

	DN	15	20	25	32	40	50	65	80	100	125	150	200
L	(mm)	130	150	160	180	200	230	290	310	350	400	480	600
H2	(mm)	195	195	205	205	235	235	265	295	380	415	480	615
B	(mm)	85	65	65	50	60	35	10	45	90	60	50	110
ØC (PN25)	(mm)	--	--	--	--	--	--	--	--	--	--	--	520
ØC (PN40)	(mm)	125	125	125	125	150	150	175	225	300	300	400	520
Travel	(mm)	6	6	8	8	13	13	16	20	25	32	40	50
Kvs-value	(m³/h)	6,4	9,5	14,5	19,5	36	54	92	127	205	324	485	789
Zeta-value	--	2	2,8	3	4,4	3,2	3,4	3,4	4,1	3,8	3,7	3,4	4,1

Zeta-value ... range of tolerance for Kvs-values acc. to VDI/VDE 2173

Face-to-face dimension ETE series 1 according to DIN EN 12982

Weights

Figure-No.	DN	15	20	25	32	40	50	65	80	100	125	150	200
55.066	(kg)	3,2	3,6	4	4,8	6,8	8,5	10	13,8	32	45	66	157

Stop valve - angle pattern with flanges and bellows seal (Grey cast iron, SG iron, Cast steel)

Figure-No.	Nominal pressure	Material	Nominal diameter
12.047	PN16	EN-JL1040	DN15-300
22.047	PN16	EN-JS1049	DN15-300
	Test: • DIN DVGW-Reg. DG-4314AO 0771		
34.047	PN25	1.0619+N	DN200-300
	Test: • DIN DVGW-Reg. DG-4314AO 0773		
35.047	PN40	1.0619+N	DN15-150
	Test: • DIN DVGW-Reg. DG-4314AO 0774		
Test: • TA - Luft TÜV-Test-No. 973-10183778			
Plug with marginal seat standard			
At high differential pressures a balancing plug is necessary! (refer to page 12)			

Selection of possible applications

Industry, Powerstations, Flue gas purification plant, processing technology, gas supply, vapour facilities, recycling facilities, vacuum facilities, hot water, heating technology, district heating, thermal oil applications, general plant manufacturing, etc.
(other applications on request)

Selection of possible flow media

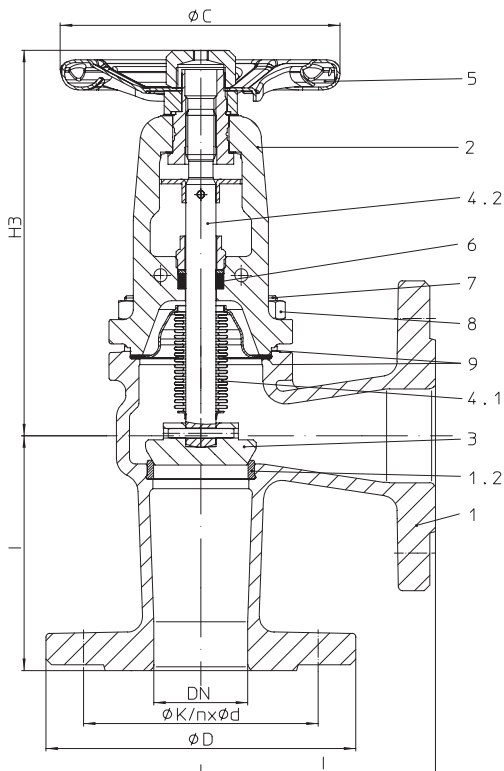
Steam, gases, hot water, thermal fluids, hot oil, process water, vacuum facilities, ammonia etc. (other flow media on request)

Parts

Pos.	Description	Fig. 12.047	Fig. 22.047	Fig. 34.047 / Fig. 35.047
1	Body	EN-JL1040, EN-GJL-250	EN-JS1049, EN-GJS-400-18U-LT	GP240GH+N, 1.0619+N
1.2	Seat ring	X20Cr13+QT, 1.4021+QT	X20Cr13+QT, 1.4021+QT	≤DN65: X20Cr13+QT, 1.4021+QT ≥DN80: G19 9 NbSi, 1.4551
2	Bonnet	EN-JS1049, EN-GJS-400-18U-LT	EN-JS1049, EN-GJS-400-18U-LT	GP240GH+N, 1.0619+N
3	Plug *	≤DN200: X20Cr13+QT, 1.4021+QT (hardened) / >DN200: P265GH, 1.0425 / G19 9 Nb Si, 1.4551		
4.1	Bellows seal	X6CrNiMoTi17 12 2, 1.4571		
4.2	Stem	X20Cr13+QT, 1.4021+QT		
5	Handwheel *	≤DN125: St (cataphoretic coating) / ≥DN150: EN-JL1040, EN-GJL-250 (epoxy-coating)		
6	Packing ring	Pure graphite		
7	Hexagon bolt	5.6	--	
7	Stud	--	25CrMo4, 1.7218	
8	Hexagon nut	--	C35E, 1.1181	
9	Gasket *	Pure graphite (CrNi laminated with graphite)		

* Spare part

Information / restriction of technical rules need to be observed!

Operating instructions can be ordered by phone +49 (0)5207 / 994-0 or fax +49 (0)5207 / 994-158 or -159.

ARI-Valves of EN-JL1040 are not allowed to be operated in systems acc. to TRD 110.

A production allowance acc. to TRB 801 No. 45 exists (acc. to TRB 801 No. 45 EN-JL1040 is not allowed.)

The engineer, designing a system or a plant, is responsible for the selection of the correct valve.

Dimensions

	DN	15	20	25	32	40	50	65	80	100	125	150	200	250	300
l	(mm)	90	95	100	105	115	125	145	155	175	200	225	275	325	375
H3	(mm)	190	190	195	195	210	210	220	235	325	345	370	485	615	665
ØC (PN16)	(mm)	125	125	125	125	150	150	175	175	225	300	400	520	520	520
ØC (PN25)	(mm)	125	125	125	125	150	150	175	175	300	300	400	520	520	520
ØC (PN40)	(mm)	125	125	125	125	150	150	175	225	300	300	400	520	--	--
Travel	(mm)	6	6	8	8	13	13	16	20	25	32	40	50	70	80
Kvs-value	(m³/h)	6	9	14	19	35	53	94	143	245	390	590	845	1360	1825
Zeta-value	--	2,2	3,2	3,2	4,6	3,3	3,6	3,2	3,2	2,7	2,6	2,3	3,6	3,4	3,9

Zeta-value ... range of tolerance for Kvs-values acc. to VDI/VDE 2173

Standard-flange dimensions refer to page 14

Face-to-face dimension CTF Grundreihe 8 acc. to DIN EN 558

Weights

Figure-No.	DN	15	20	25	32	40	50	65	80	100	125	150	200	250	300
12. / 22.047	(kg)	3,7	4,4	5,1	6,5	8,3	11,2	14,6	19,4	29,4	44	58	145	221	298
34.047	(kg)	--	--	--	--	--	--	--	--	--	--	--	155	273	309
35.047	(kg)	4,6	6,4	6,7	7,5	10,1	12,7	17,5	22	34	49	60	--	--	--

L = Face-to-face dimension
 Edge shaping acc. to DIN EN ISO 5817

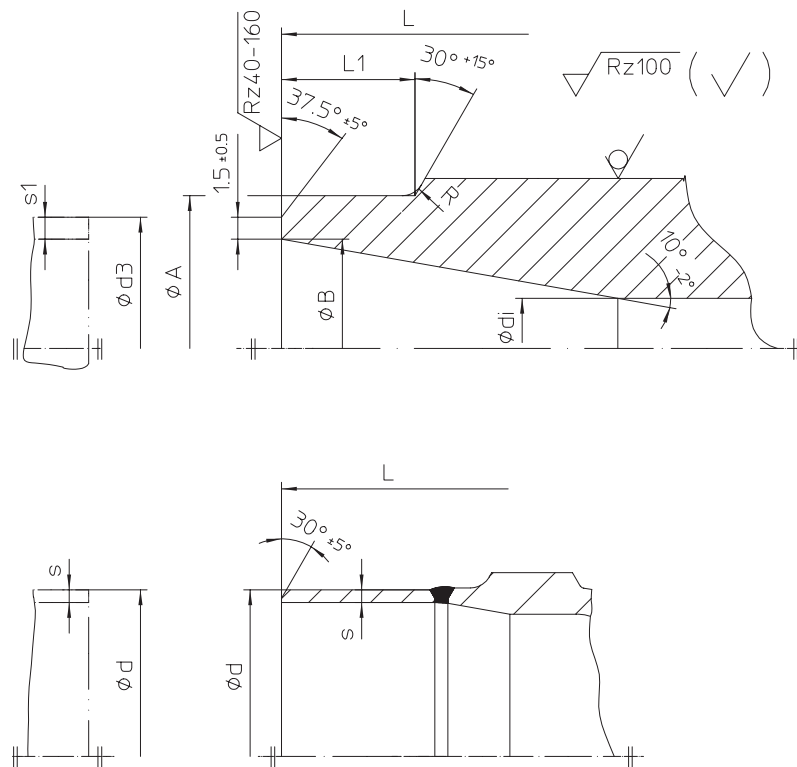
Butt weld ends according to DIN EN 12627 - 4

	DN	15	20	25	32	40	50	65	80	100	125	150	200	250	300	350	400
L	(mm)	130	150	160	180	200	230	290	310	350	400	480	600	730	850	980	1100
ØA	(mm)	22	28	35	44	50	62	77	91	117	144	172	223	278	329	362	413
ØB	(mm)	17,3	22,3	28,5	37,2	43,1	53,9	68,9	80,9	104,3	130,7	157,1	204,9	257,	307,9	338,	384,4
Ødi	(mm)	15	20	25	32	40	50	65	80	100	125	150	200	250	300	330	375
R	(mm)	3	3	3	3	3	3	3	3	3	3	3	5	5	5	5	5
L1	(mm)	10	10	10	10	10	10	10	12	14	18	20	20	25	33	45	45
Ød3	(mm)	21,3	26,9	33,7	42,4	48,3	60,3	76,1	88,9	114,3	139,7	168,3	219,1	273	323,9	355,6	406,4
s1	(mm)	2	2,3	2,6	2,6	2,6	3,2	3,6	4	5	4,5	5,6	7,1	8	8	8,8	11

Shoed ends of P235GH (Pipe connection ≙ welding neck flanges)

	DN	15	20	25	32	40	50	65	80	100	125	150	200	250	300	350	400
Ød	(mm)	--	--	--	--	--	--	76,1	88,9	114,3	139,7	168,3	219,1	--	--	--	--
Øs	(mm)	--	--	--	--	--	--	2,9	3,2	3,6	4	4,5	6,3	--	--	--	--

Face-to-face dimension ETE series 1 according to DIN EN 12982.

Butt weld ends according to DIN EN 12627 - 4.

Weld joint according to DIN EN 29692 code number 1.3.3.

The material used for ARI valves with butt weld ends are:

GP240GH+N, 1.0619+N acc. to DIN EN 10213-2,

P250GH, 1.0460 acc. to DIN EN 10222-2.

The material used for ARI valves with shoed ends (DN 65-200) P235GH according to DIN EN 10216-2.

Based on our experience we recommend electric welding process for connecting valves or strainers with tubes or with each other

Lime based electrodes with an appropriate composite material should be used as filler material for welding.

Gas welding should be avoided.

Due to the different material composition and material thickness of valves and tubes, gas welding is more susceptible to produce faults than electric welding (hardness cracks, coarse-grained structure).

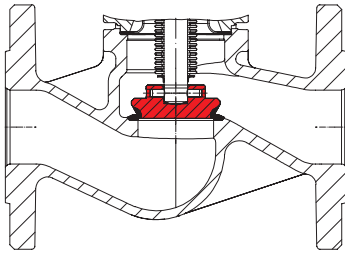

Isolation plug with marginal seat; stellite seat and plug

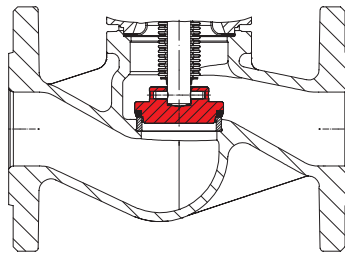

Plug with soft seal PTFE + 25% carbon, Max. operating temperature 200°C at PTFE + 25% carbon

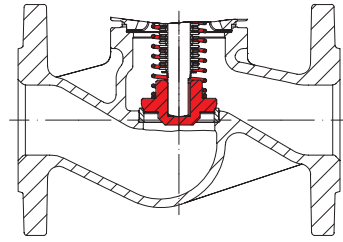

Screw down non-return plug with re-setting spring (Set pressure refer to: Flow diagram)

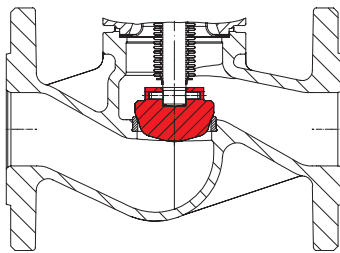
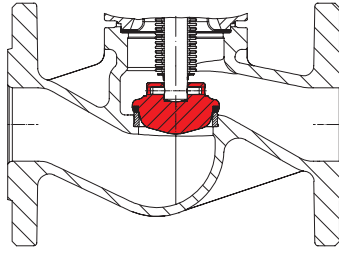
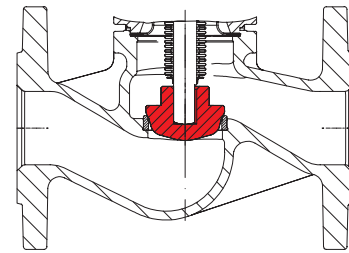
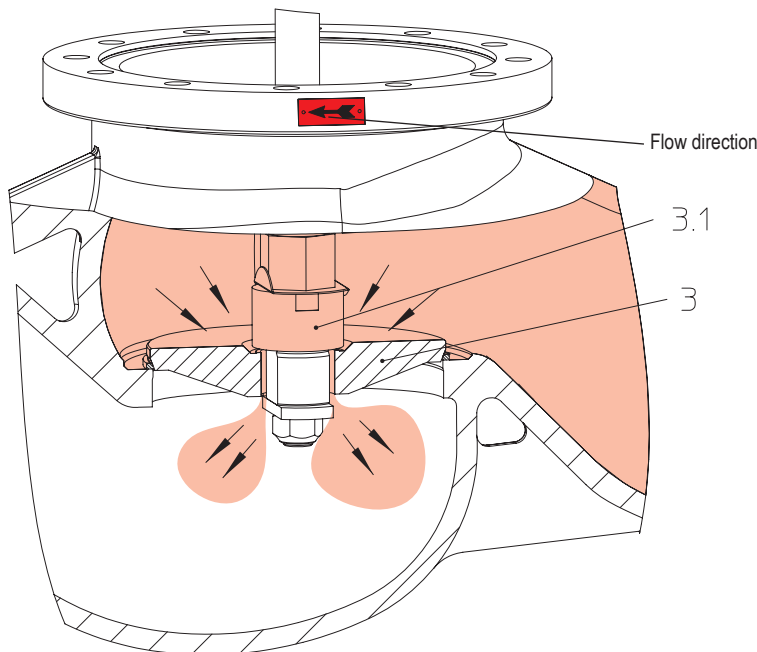
 Regulating plug with marginal seat (for max. permissible ΔP refer to: Flow diagram)

 Regulating plug with marginal seat and soft seal PTFE + 25% carbon, Max. operating temperature 200°C at PTFE + 25% carbon (for max. permissible ΔP refer to: Flow diagram)

 Screw down non-return regulating plug with marginal seat (for set pressure and max. permissible ΔP refer to: Flow diagram)

Valves with balancing plugs have to be installed with medium flowing over the plug (3) as indicated by flow direction arrow on valve body and the stem is vertically upright.
 Working principles:

When the valve is closed, anticlockwise rotation of the hand wheel lifts the pilot plug (3.1) off the larger balancing plug (3).

This allows the medium to pass through the plug and equalizes the pressure of the medium under the plug (3). After the pressures have been equalized within the values stated in the table, the valve can be opened by turning the valve further with normal manual force.

Balancing plugs are fully effective only in closed systems.

The pressures of the medium on either side of the plug can not be equalized if the medium is discharged into open air.

A bypass line or some other arrangement is necessary if too much time is required for pressure equalization owing to the volume in the piping system.

ARI-stop valves with differential pressures exceeding the following pressures, have to be fitted with pressure balancing plugs

	DN	125	150	200	250	300	350	400	500
Differential pressure (ΔP)	(bar)	25	21	14	9	6	4,5	3,5	1,5

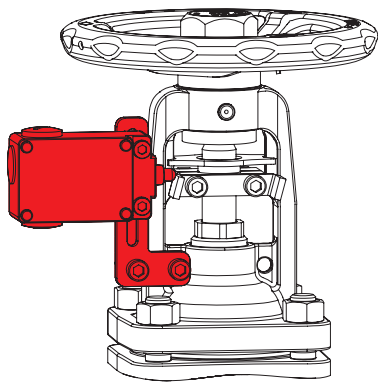

Limit switch

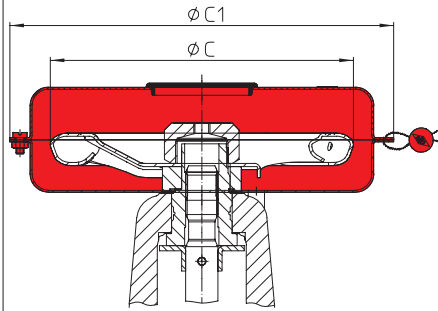

Hood valve acc.to DIN EN 12828
(tamper-proof handwheel cover)

Size	DN	ØC	ØC1
	(mm)	(mm)	(mm)
I	15-50	125	170
II	65-80	150	190
III	100-150	225	330

Handwheel-Ø from DN 65 reduced!

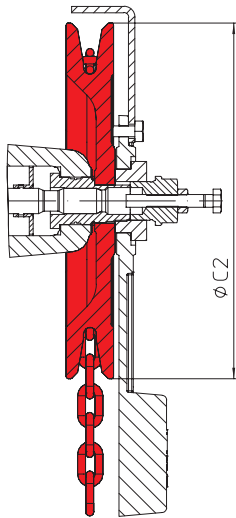

Chain wheel

DN	ØC2	Weight
(mm)	(mm)	(kg)
15-32	180	2,5
40-80	220	7
100-150	260	8,9
200-400	300	11

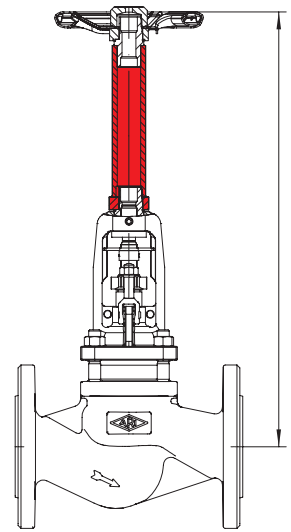

Stem extension (please specify height in your order)

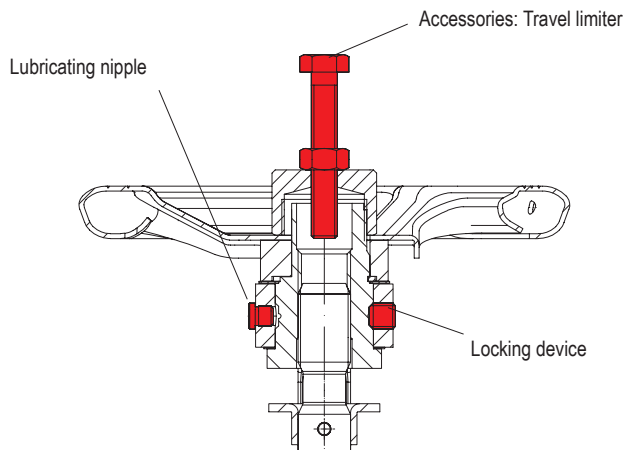

Lubricating nipple / Locking device / Travel limiter

Travel limiter
(Accessories are not included !)

DN	Hexagon bolt
(mm)	(mm x mm)
15-80	M8 x 55
100	M12 x 70
125-150	M12 x 80
200	M12 x 100
250-300	M12 x 120
350-400	M16 x 160

Standard-flange dimensions

Flanges acc. to DIN EN 1092-1/-2 (Flangeholes / -thickness tol. acc. To DIN 2533/2544/2545)

DN		(mm)	15	20	25	32	40	50	65	80	100	125	150	200	250	300	350	400	500
PN6	ØD	(mm)	80	90	100	120	130	140	160	190	210	240	265	320	--	--	--	--	--
PN6	ØK	(mm)	55	65	75	90	100	110	130	150	170	200	225	280	--	--	--	--	--
PN6	n x Ød	(mm)	4x11	4x11	4x11	4x14	4x14	4x14	4x14	4x18	4x18	8x18	8x18	8x18	--	--	--	--	--
PN16	ØD	(mm)	95	105	115	140	150	165	185	200	220	250	285	340	405	460	520	580	715
PN16	ØK	(mm)	65	75	85	100	110	125	145	160	180	210	240	295	355	410	470	525	650
PN16	n x Ød	(mm)	4x14	4x14	4x14	4x18	4x18	4x18	4x18	8x18	8x18	8x18	8x22	12x22	12x26	12x26	16x26	16x30	20x33
PN25	ØD	(mm)	95	105	115	140	150	165	185	200	235	270	300	360	425	485	555	620	730
PN25	ØK	(mm)	65	75	85	100	110	125	145	160	190	220	250	310	370	430	490	550	660
PN25	n x Ød	(mm)	4x14	4x14	4x14	4x18	4x18	4x18	8x18	8x18	8x22	8x26	8x26	12x26	12x30	16x30	16x33	16x36	20x36
PN40	ØD	(mm)	95	105	115	140	150	165	185	200	235	270	300	375	450	515	580	660	755
PN40	ØK	(mm)	65	75	85	100	110	125	145	160	190	220	250	320	385	450	510	585	670
PN40	n x Ød	(mm)	4x14	4x14	4x14	4x18	4x18	4x18	8x18	8x18	8x22	8x26	8x26	12x30	12x33	16x33	16x36	16x39	20x42

Pressure-temperature-ratings acc. to DIN EN 1092-2

Material			-60°C to <-10°C*	-10°C to 120°C	150°C	200°C	250°C	300°C	350°C	400°C	450°C
EN-JL1040	16	(bar)	--	16	14,4	12,8	11,2	9,6	--	--	--
EN-JS1049	16	(bar)	on request	16	15,5	14,7	13,9	12,8	11,2	--	--
EN-JS1049	25	(bar)	on request	25	24,3	23	21,8	20	17,5	--	--
EN-JS1049	40	(bar)	on request	40	38,8	36,8	34,8	32	28	--	--

Pressure-temperature-ratings acc. to manufacturers standard

Material			-60°C to <-10°C*	-10°C to 120°C	150°C	200°C	250°C	300°C	350°C	400°C	450°C
1.0619+N	25	(bar)	18,7	25	23,9	22	20	17,2	16	14,8	8,2
1.0619+N	40	(bar)	30	40	38,1	35	32	28	25,7	23,8	13,1
1.0460	25	(bar)	18,7	25	23,9	22	20	17,2	16	14,8	10
1.0460	40	(bar)	30	40	38,1	35	32	28	25,7	23,8	16

Pressure-temperature-ratings acc. to DIN EN 1092-1

Material			-60°C to <-10°C*	-10°C to 100°C	150°C	200°C	250°C	300°C	350°C	400°C	450°C
1.4408	16	(bar)	16	16	14,5	13,4	12,7	11,8	11,4	10,9	--
1.4408	25	(bar)	25	25	22,7	21	19,8	18,5	17,8	17,1	--
1.4408	40	(bar)	40	40	36,3	33,7	31,8	29,7	28,5	27,4	--
1.4581	16	(bar)	8	16	15,6	14,9	14,1	13,3	12,8	12,4	--
1.4581	25	(bar)	12,5	25	24,5	23,3	22,1	20,8	20,1	19,5	--
1.4581	40	(bar)	20	40	39,2	37,3	35,4	33,3	32,1	31,2	--

Intermediate values for max. permissible operational pressures can be determined by linear interpolation of the given temperature / pressure chart.

* Studs and nuts made of A4-70 (at temperatures below -10°C)

Please indicate when ordering

- Figure-No.
- Nominal pressure
- Nominal diameter
- Special design / accessories

Example:

Figure 35.046; nominal pressure PN40; nominal diameter DN100.

 Dimensions in mm
 Weights in kg
 1 bar $\hat{=}$ 10⁵ Pa $\hat{=}$ 0,1 MPa
 Kvs in m³/h

Technology for the Future.
 GERMAN QUALITY VALVES

 ARI-Armaturen Albert Richter GmbH & Co. KG, D-33756 Schloß Holte-Stukenbrock,
 Tel. +49 52 07 / 994-0, Telefax +49 52 07 / 994-158 or 159 Internet: <http://www.ari-armaturen.com> E-mail: info.vertrieb@ari-armaturen.com