

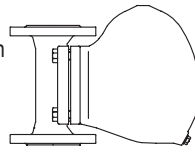
Ball float steam trap

**Ball float steam trap**  
**PN16 / PN40**

- with flanges
- with screwed sockets
- with socket weld ends
- with butt weld ends

(Fig. 631....1)  
(Fig. 631....2)  
(Fig. 631....3)  
(Fig. 631....4)

Grey cast iron  
SG iron  
Cast steel/  
Forged steel  
High temperature steel  
Stainless steel



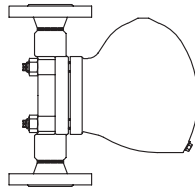
**Fig. 631** Page 2

**Ball float steam trap**  
**PN63 / PN100**

- with flanges
- with socket weld ends
- with butt weld ends

(Fig. 631....1)  
(Fig. 631....3)  
(Fig. 631....4)

High temperature steel/  
Cast steel



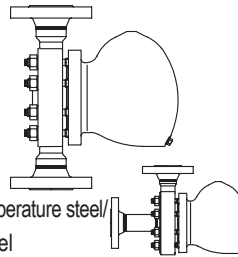
**Fig. 631** Page 6

**Ball float steam trap**  
**PN160**

- with flanges
- with socket weld ends
- with butt weld ends

(Fig. 631....1)  
(Fig. 631....3)  
(Fig. 631....4)

High temperature steel/  
Cast steel



**Fig. 631 / Fig. 632** Page 8

**Angle pattern design:**

- with flanges
- with butt weld ends

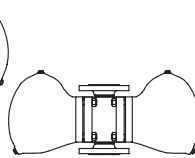
(Fig. 632....1)  
(Fig. 632....4)

**Ball float steam trap**  
**PN16 / PN40**

- with flanges R4-P
- with flanges

(Fig. 633....1)  
(Fig. 639....1)

Forged steel/  
Grey cast iron  
Forged steel/  
Cast steel  
Stainless steel



**Fig. 633 / Fig. 639** Page 10  
Page 12

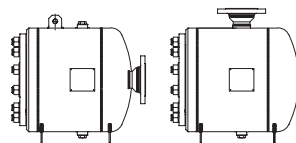
**Ball float steam trap**  
**PN40**

- with flanges
- Angle pattern design:**
- with flanges

(Fig. 637....1)  
(Fig. 638....1)

Steel

**Fig. 637 / Fig. 638** Page 14



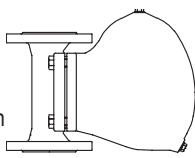
**Ball float steam trap for drainage of water**  
**from compressed air and gas systems**  
(acc. to PED 97/23/EC fluid group 2)

**PN16 / PN40**

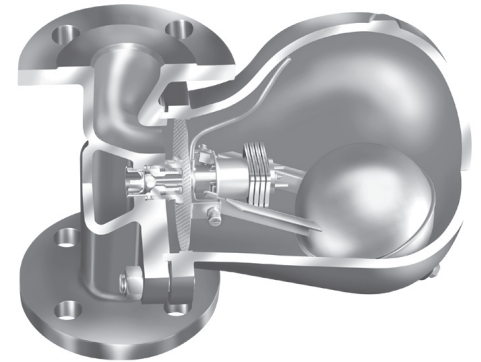
- with flanges
- with screwed sockets
- with socket weld ends
- with butt weld ends

(Fig. 630....1)  
(Fig. 630....2)  
(Fig. 630....3)  
(Fig. 630....4)

Grey cast iron  
SG iron  
Forged steel/Cast steel  
Stainless steel



**Fig. 630** Page 16



**Fig. 631....1**

**Features:**

- Back pressure-free condensate discharge even at extreme pressure- and quantity fluctuations
- Controller with integrated automatic ventilation (except Fig. 630)
- Robust and insensitive to waterhammer
- Non return protection (except Fig. 633/637/638)
- Union for pressure compensation line and bypass possible
- On-site change of the installation position is possible according to the operating instructions (except Fig. 633/637/638)
- The controller maybe changed without disturbing the pipe work

**Ball float steam trap (Grey cast iron, SG iron, Cast steel/Forged steel, Stainless steel)**

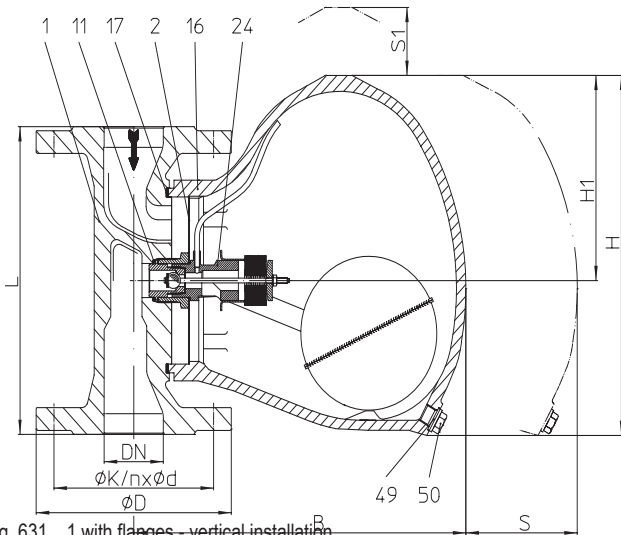


Fig. 631....1 with flanges - vertical installation

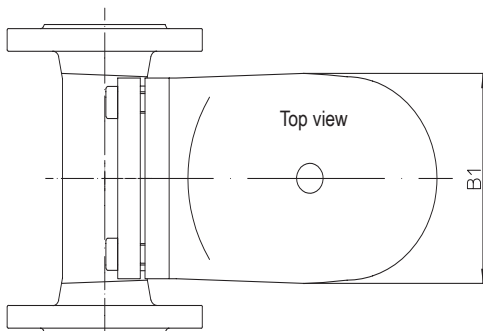
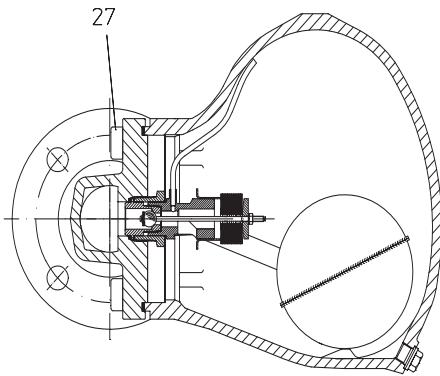


Fig. 631....1 with flanges - horizontal installation

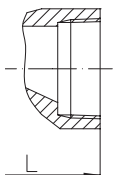


Fig. 631....2 with screwed sockets

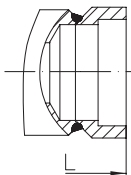


Fig. 631....3 with socket weld ends

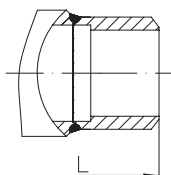


Fig. 631....4 with butt weld ends

- Ball float steam trap with level control for the condensate-discharge from all kinds of steam systems
- Rapid system start-up due to thermostatic control element
- Standard installation position: - vertical
- Optional installation position: - horizontal with inlet from right or left (Please indicate when ordering).
- Inside strainer
- Body with flanged hood
- Non return protection
- The controller may be changed without disturbing the pipe work
- On-site change of the installation position is possible according to the operating instructions
- Options: - Air vent - (Pos. 51) or blow down valve (Pos. 46), manual operated

**Operating limits**

Fig. 12.631	PN16 Body/Hood: EN-JL1040	
Operating pressure PS (bar-g)	12,8	9,6
Operating temperature TS (°C)	200	300

allowable differential pressure ΔPMX (bar):	2	4	8	13
for controller:	R2 R2-S	R4 R4-S	R8 R8-S	R13 R13-S

Fig. 25.631	PN40 Body/Hood: EN-JS1049	
Operating pressure PS (bar-g)	32	22
Operating temperature TS (°C)	250	350

allowable differential pressure ΔPMX (bar):	2	4	8	13	22	32
for controller:	R2 R2-S	R4 R4-S	R8 R8-S	R13 R13-S	R22	R32

Fig. 45.631	PN40 Body: 1.0460 / Hood: 1.0619+N	
Operating pressure PS (bar-g)	32	21
Operating temperature TS (°C)	250	400

allowable differential pressure ΔPMX (bar):	2	4	8	13	22	32
for controller:	R2 R2-S	R4 R4-S	R8 R8-S	R13 R13-S	R22	R32

Fig. 55.631	PN40 Body: 1.4541 / Hood:1.4308	
Operating pressure PS (bar-g)	32	28
Operating temperature TS (°C)	250	300

allowable differential pressure ΔPMX (bar):	2	4	8	13	22	32
for controller:	R2 R2-S	R4 R4-S	R8 R8-S	R13 R13-S	R22	R32

**Types of connection**

Flanges ....1	PN16 / PN40 acc. to DIN 2501
Screwed sockets ....2	Rp- and NPT-thread acc. to DIN EN 10226-1
Socket weld ends ....3	acc. to DIN EN 12760
Butt weld ends ....4	acc. to DIN EN 12627

Other types of connection on request.

**For ANSI versions refer to data sheet CONA®S-ANSI**

Dimensions and Weights		Types of connection																	
		Flanges								Screwed sockets <sup>1)</sup> Socket weld ends <sup>2)</sup>					Butt weld ends <sup>2)</sup>				
Nominal diameter	(mm) (inch)	15 1/2	20 3/4	25 1	40 1 1/2	50 2	65 <sup>2)</sup> 2 1/2	80 <sup>2)</sup> 3	100 <sup>2)</sup> 4	15 1/2	20 3/4	25 1	40 1 1/2	50 <sup>1)</sup> 2 <sup>1)</sup>	15 1/2	20 3/4	25 1	40 1 1/2	50 2
L*	(mm)	150	150	160	230	230	290	310	350	150	150	160	210	210 <sup>3)</sup>	160	160	160	250	250
H	(mm)	162	162	187	270	270	270	270	270	162	162	187	270	270	162	162	187	270	270
H1	(mm)	85	85	102	151	151	151	151	151	85	85	102	151	151	85	85	102	151	151
B (EN-JS1049)	(mm)	214	214	255	280	280	--	--	--	214	214	255	280	--	--	--	--	--	--
B (steel)	(mm)	214	214	255	280	280	280	280	280	167	167	196	285	285	167	167	196	285	285
B1	(mm)	95	95	118	157	157	157	157	157	95	95	118	157	157	95	95	118	157	157
S	(mm)	180	180	200	300	300	300	300	300	180	180	200	300	300	180	180	200	300	300
S1	(mm)	150	150	180	200	200	200	200	200	150	150	180	200	200	150	150	180	200	200
Weight approx.	(kg)	7,9	8,1	10,9	24,7	25,3	27,2	29,2	32,7	7,3	7,3	8,5	20	20,5	6,9	7,9	9	21	22

Standard-flange dimensions refer to page 21. <sup>1)</sup> DN50 (2") not for EN-JL/JS  
<sup>2)</sup> not for EN-JL/JS  
<sup>3)</sup> EN-JS: L = 230 mm

\* Face-to-face acc. to data sheet resp. customer request

### Parts

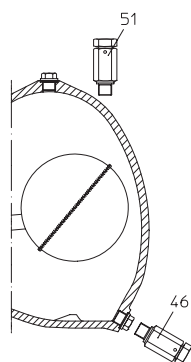
Pos.	Description	Fig. 12.631	Fig. 25.631	Fig. 45.631	Fig. 55.631
1	Body	EN-GJL-250, EN-JL1040	EN-GJS-400-18U-LT, EN-JS1049	P250 GH, 1.0460	X6CrNiTi18-10, 1.4541
2	Strainer	X5CrNi18-10, 1.4301			
11	Sealing ring *	R-Cu99			X6CrNiTi18-10, 1.4541
16	Hood	EN-GJL-250, EN-JL1040	EN-GJS-400-18U-LT, EN-JS1049	GP240GH+N, 1.0619+N	GX5CrNi19-10, 1.4308
17	Gasket *	Graphite (CrNi laminated with graphite)			
24	Controller *	TB 102 / 85 (corrosion resistant bimetal)			
27	Cheese head screw	X6CrNiTi18-10, 1.4541 / 8.8	21CrMoV 5-7, 1.7709	21CrMoV 5-7, 1.7709	X6CrNiTi18-10, 1.4541
46	Blow down valve, cpl. *	X8CrNiS18-9, 1.4305			
49	Sealing ring *	R-Cu99			X6CrNiTi18-10, 1.4541
50	Plug (M14x1,5) *	C35E, 1.1181	21CrMoV 5-7, 1.7709		X6CrNiTi18-10, 1.4541
51	Manual air vent valve *	X8CrNiS18-9, 1.4305			

\* Spare part

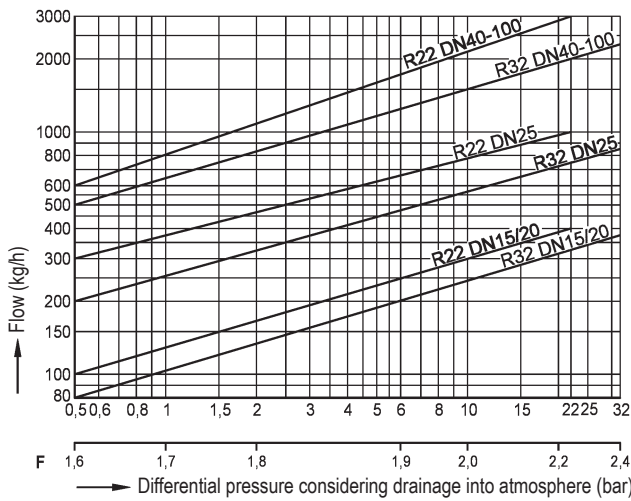
Information / restriction of technical rules need to be observed!

Operating instructions can be ordered by phone +49 (0)5207 / 994-0 or fax +49 (0)5207 / 994-158 or -159.

### Options



**Capacity chart**  
**Standard R22 and R32**  
**DN15 - DN100**



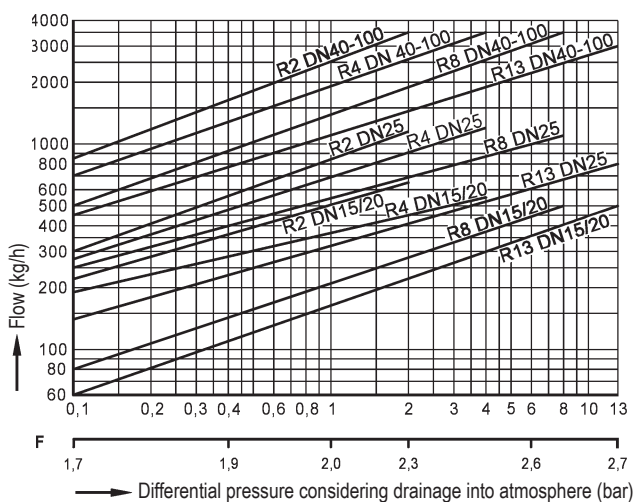
The capacity chart shows the maximum flow quantities of hot condensate for the different controllers and steam trap sizes

In common, the steam traps are fitted out with an controller as shown in the flow diagrams of this page acc. to the differential pressures and flow rates.

For very large flow rates with low differential pressures, steam traps at sizes DN40 up to DN100 can be fitted out with a super-controller

The maximum flow quantity of cold condensate at about 20°C can be determined by multiplication of the appropriate factor F (in the scale below the diagrams) with the hot condensate quantity determined by the capacity chart. (Factor F is related to the differential pressure)

**Capacity chart**  
**Standard R2 to R13**  
**DN15 - DN100**



The capacity chart shows the maximum flow quantities of hot condensate for the different controllers and steam trap sizes

In common, the steam traps are fitted out with an controller as shown in the flow diagrams of this page acc. to the differential pressures and flow rates.

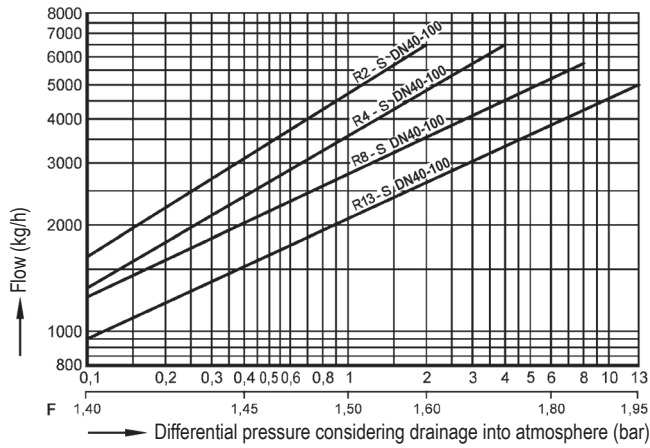
For very large flow rates with low differential pressures, steam traps at sizes DN40 up to DN100 can be fitted out with a super-controller

The maximum flow quantity of cold condensate at about 20°C can be determined by multiplication of the appropriate factor F (in the scale below the diagrams) with the hot condensate quantity determined by the capacity chart. (Factor F is related to the differential pressure)

Special design: Super-controller for very large flow rates with low differential pressures

R2-S to R13-S

DN 40 - 100



The capacity chart shows the maximum flow quantities of hot condensate for the Super-controller versions.

The maximum flow quantity of cold condensate at about 20°C can be determined by multiplication of the appropriate factor F (in the scale below the diagrams) with the hot condensate quantity determined by the capacity chart. (Factor F is related to the differential pressure)

**Ball float steam trap (High temperature steel)**

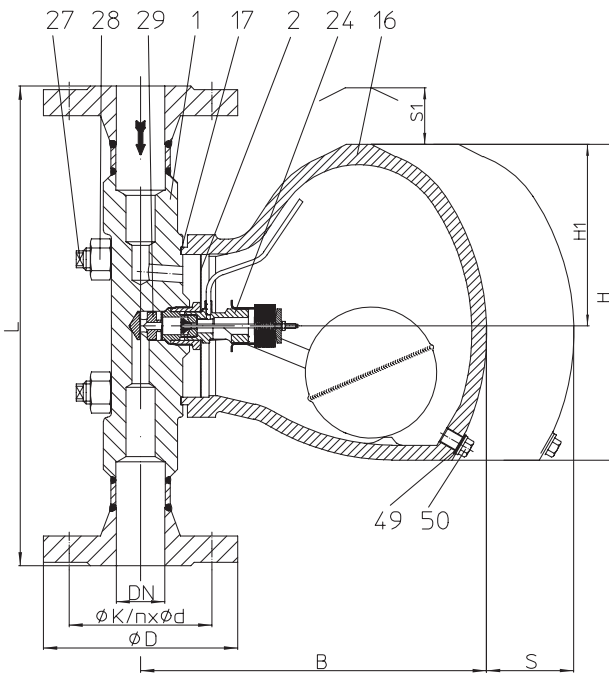


Fig. 631....1 with flanges - vertical installation (PN100)

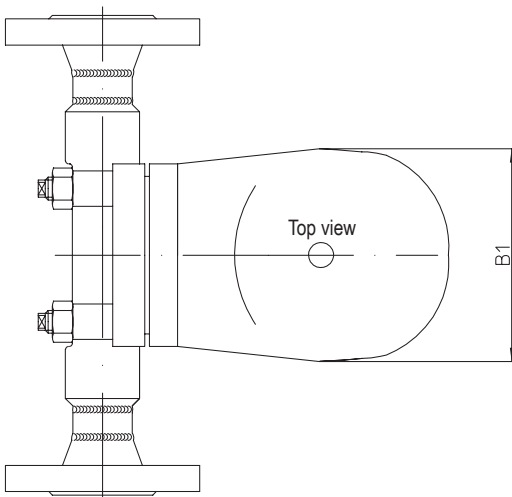
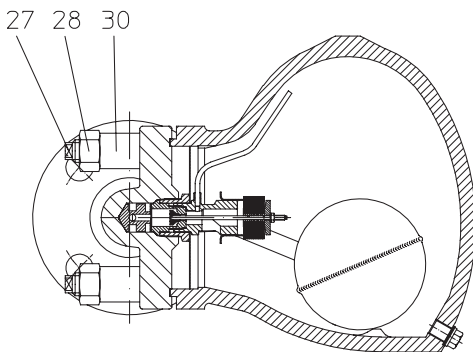


Fig. 631....1 with flanges - horizontal installation (PN100)

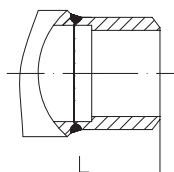


Fig. 631....4  
with butt weld ends

- Ball float steam trap with level control for the condensate-discharge from all kinds of steam systems
- Rapid system start-up due to thermostatic control element (for condensate with temperatures  $\geq 100^{\circ}\text{C}$ )
- Standard installation position: - vertical
- Optional installation position: - horizontal with inlet from right or left (Please indicate when ordering).
- Inside strainer
- Body with flanged hood
- Non return protection
- The controller may be changed without disturbing the pipe work
- On-site change of the installation position is possible according to the operating instructions
- Options: - Air vent - (Pos. 51) or blow down valve (Pos. 46), manual operated

**Operating limits**

Fig. 86.631	PN63 Body: 16Mo3 / Hood: G17CrMo5-5		
Operating pressure PS (bar-g)	56	50	45
Operating temperature TS ( $^{\circ}\text{C}$ )	300	350	450

allowable differential pressure $\Delta\text{PMX}$ (bar):	50
for controller:	R50

Fig. 87.631	PN100 Body: 16Mo3 / Hood: G17CrMo5-5	
Operating pressure PS (bar-g)	64	50
Operating temperature TS ( $^{\circ}\text{C}$ )	400	450

allowable differential pressure $\Delta\text{PMX}$ (bar):	64	50
for controller:	R64	R50

Fig. 87.631	PN100 Body: 13CrMo4-5 / Hood: G17CrMo5-5		
Operating pressure PS (bar-g)	80	60	30
Operating temperature TS ( $^{\circ}\text{C}$ )	480	510	525

allowable differential pressure $\Delta\text{PMX}$ (bar):	80	64	50
for controller:	R80	R64	R50

**Types of connection**

Flanges ....1	PN63 / PN100 acc. to DIN 2501
Butt weld ends ....4	acc. to DIN EN 12627

Other types of connection on request.

For ANSI versions refer to data sheet CONA®S-ANSI

Dimensions and Weights		Types of connection								
		Flanges				Butt weld ends				
Nominal diameter	(mm) (inch)	15 1/2	25 1	40 1 1/2	50 2	15 1/2	20 3/4	25 1	40 1 1/2	50 2
L	(mm)	300	300	420	416	216	216	216	240	250
H	(mm)	280	280	280	280	280	280	280	280	280
H1	(mm)	160	160	160	160	160	160	160	160	160
B	(mm)	302	302	302	302	302	302	302	302	302
B1	(mm)	185	185	185	185	185	185	185	185	185
S	(mm)	300	300	300	300	300	300	300	300	300
S1	(mm)	200	200	200	200	200	200	200	200	200
Weight approx.	(kg)	30	34	38	42	26	26	26	26	28

Standard-flange dimensions refer to page 21.

\* Face-to-face acc. to data sheet resp. customer request

### Parts

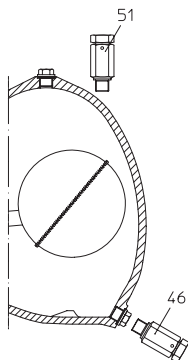
Pos.	Description	Fig. 86.631 / 87.631	Fig. 87.631
1	Body	16Mo3, 1.5415	13CrMo4-5, 1.7335
2	Strainer	X5CrNi18-10, 1.4301	
16	Hood	G17CrMo5-5, 1.7357	
17	Gasket *	Graphite (CrNi laminated with graphite)	
24	Controller *	TB 102 / 85 (corrosion resistant bimetal)	
27	Stud	X22CrMoV12-1, 1.4923	
28	Hexagonal nut	X22CrMoV12-1, 1.4923	
29	Erosion deflector * (only PN100)	X17CrNi16-2, 1.4057	
30	Extension sleeve	21CrMoV 5-7, 1.7709	
46	Blow down valve, cpl. *	X39CrMo17-1+QT, 1.4122+QT	
49	Sealing ring *	X6CrNiTi18-10, 1.4541	
50	Plug (M14x1,5) *	21CrMoV 5-7, 1.7709	
51	Manual air vent valve *	X39CrMo17-1+QT, 1.4122+QT	

\* Spare part

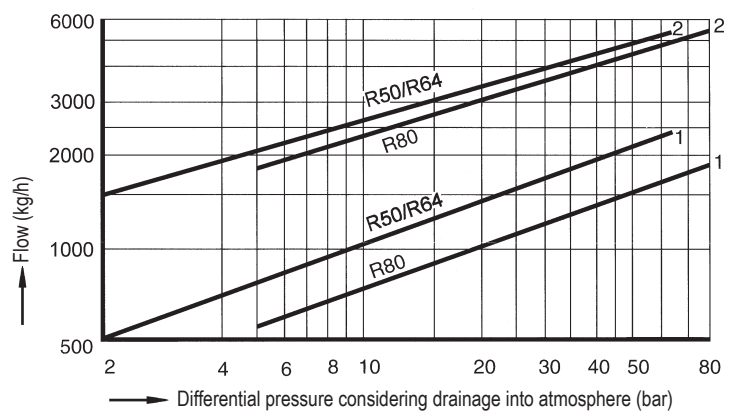
Information / restriction of technical rules need to be observed!

Operating instructions can be ordered by phone +49 (0)5207 / 994-0 or fax +49 (0)5207 / 994-158 or -159.

### Options



### Capacity chart

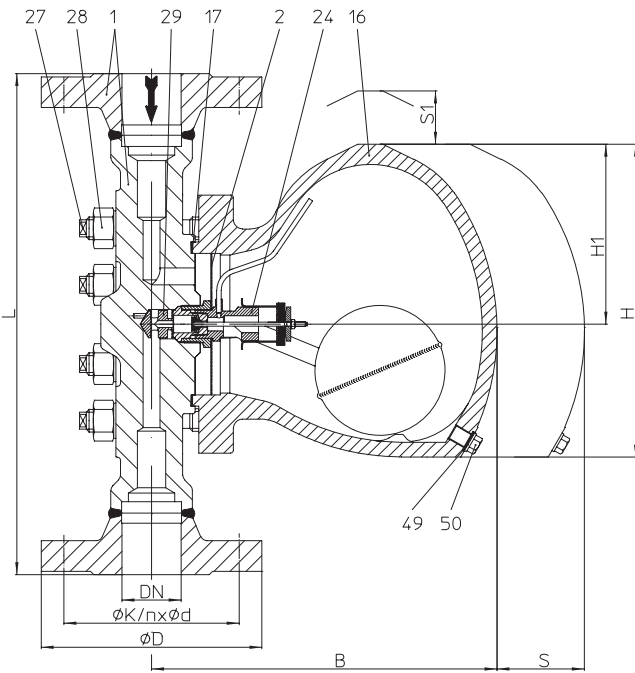


The capacity chart shows the maximum flow rates.

**Curve 1:**  
Maximum flow quantities of hot condensate.

**Curve 2:**  
Maximum flow quantities of cold condensate of about 20°C (during system start-up).

Ball float steam trap (High temperature steel)



- Ball float steam trap with level control for the condensate-discharge from all kinds of steam systems
- Rapid system start-up due to thermostatic control element
- Standard installation position: - vertical
- Optional installation position: - horizontal with inlet from right or left (Please indicate when ordering).
- Inside strainer
- Body with flanged hood
- Non return protection
- The controller may be changed without disturbing the pipe work
- On-site change of the installation position is possible according to the operating instructions
- Options: - Air vent - (Pos. 51) or blow down valve (Pos. 46), manual operated

Operating limits

Fig. 88.631 / 88.632	PN160 Body: 13CrMo4-5 / Hood: G17CrMo5-5		
Operating pressure PS (bar-g)	110	80	35
Operating temperature TS (°C)	506	519	550
allowable differential pressure ΔPMX (bar):	110		80
for controller:	R110		R80

Types of connection

Flanges ....1	PN160 acc. to DIN 2501
Socket weld ends ....3	acc. to DIN EN 12760
Butt weld ends ....4	acc. to DIN EN 12627

Other types of connection on request.

For ANSI versions refer to data sheet CONA®S-ANSI

Fig. 631....1 with flanges - vertical installation

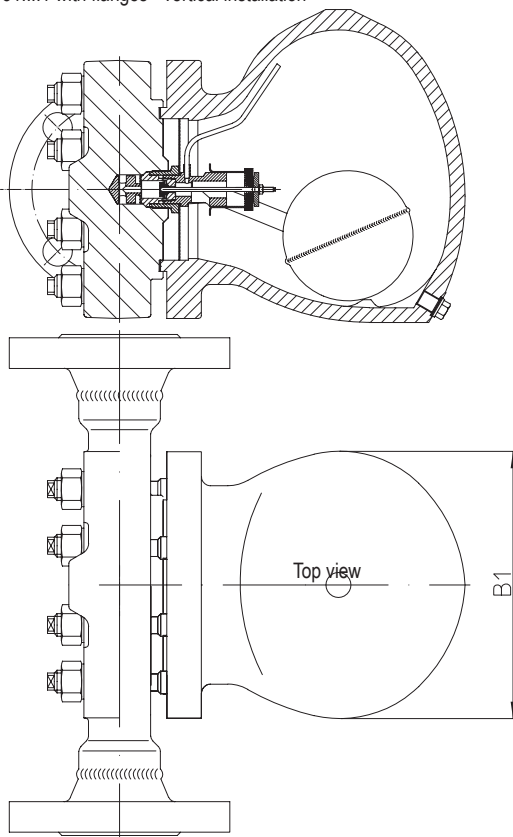


Fig. 631....1 with flanges - horizontal installation

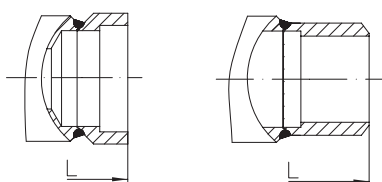


Fig. 631....3  
with socket weld ends

Fig. 631....4  
with butt weld ends

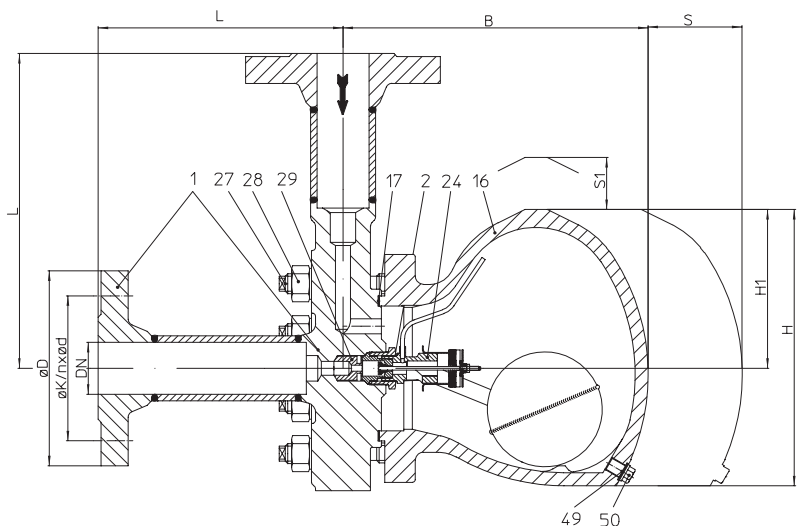


Fig. 632....1 Angle pattern design with flanges - vertical installation

Dimensions and Weights		Types of connection					
		Flanges			Butt weld ends Screwed sockets		
Nominal diameter	(mm) (inch)	15 1/2	25 1	50 2	15 1/2	25 1	50 2
L	(mm)	400	415	440	335	335	335
L1 / L2 ECK *	(mm)	200	208	220	168	168	168
H	(mm)	280	280	280	280	280	280
H1	(mm)	160	160	160	160	160	160
B	(mm)	302	302	302	302	302	302
B1	(mm)	185	185	185	185	185	185
S	(mm)	300	300	300	300	300	300
S1	(mm)	200	200	200	200	200	200
Weight approx.	(kg)	46	49	56	53	41	38

Standard-flange dimensions refer to page 21.

\* Face-to-face acc. to data sheet resp. customer request

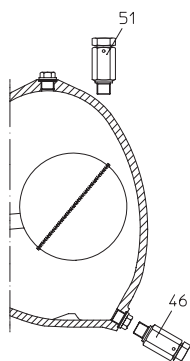
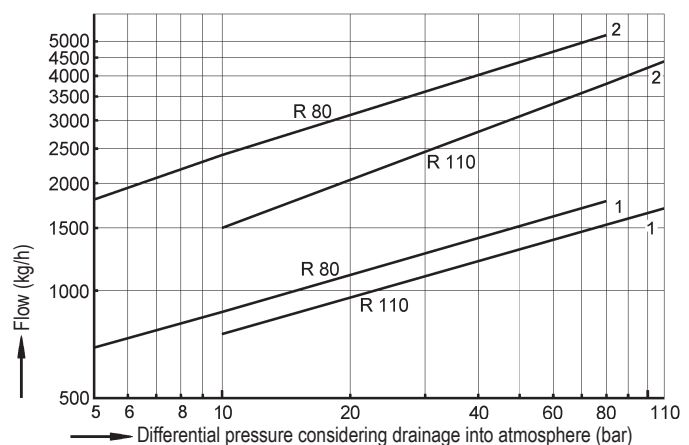
**Parts**

Pos.	Description	Fig. 86.631 / 87.631	Fig. 87.631
1	Body	16Mo3, 1.5415	13CrMo4-5, 1.7335
2	Strainer	X5CrNi18-10, 1.4301	
16	Hood	G17CrMo5-5, 1.7357	
17	Gasket *	Graphite (CrNi laminated with graphite)	
24	Controller *	TB 102 / 85 (corrosion resistant bimetal)	
27	Stud	X22CrMoV12-1, 1.4923	
28	Hexagonal nut	X22CrMoV12-1, 1.4923	
29	Erosion deflector *	X17CrNi16-2, 1.4057	
46	Blow down valve, cpl. *	X39CrMo17-1+QT, 1.4122+QT	
49	Sealing ring *	X6CrNiTi18-10, 1.4541	
50	Plug (M14x1,5) *	21CrMoV 5-7, 1.7709	
51	Manual air vent valve *	X39CrMo17-1+QT, 1.4122+QT	

\* Spare part

Information / restriction of technical rules need to be observed!

Operating instructions can be ordered by phone +49 (0)5207 / 994-0 or fax +49 (0)5207 / 994-158 or -159.

**Options**

**Capacity chart**


The capacity chart shows the maximum flow rates.

**Curve 1:**  
Maximum flow quantities of hot condensate.

**Curve 2:**  
Maximum flow quantities of cold condensate of about 20°C (during system start-up).

Ball float steam trap (Forged steel/Cast steel)

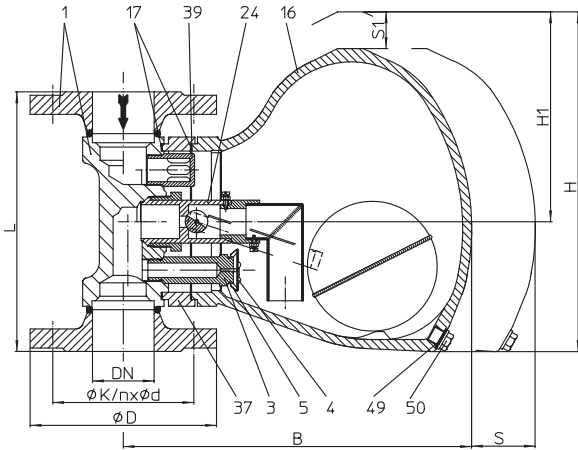


Fig. 633....1 with flanges - vertical installation

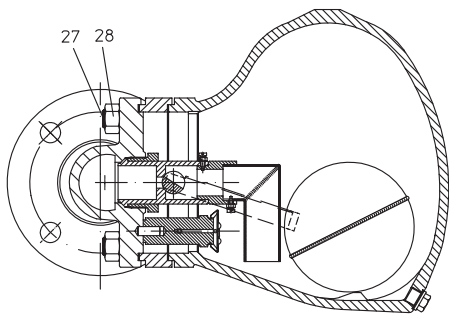


Fig. 633....1 with flanges - horizontal installation

- Ball float steam trap with level control for the condensate-discharge from all kinds of steam systems
- Rapid system start-up due to thermostatic control element
- Immediate discharge of hot boiling condensat
- Standard installation position: - vertical
- Optional installation position: - horizontal with inlet from right or left (Please indicate when ordering).
- Body with flanged hood
- The controller may be changed without disturbing the pipe work
- Installation position can not be changed later on
- Options: - Air vent - (Pos. 51) or blow down valve (Pos. 46), manual operated

Operating limits

Fig. 45.633	PN40 Body: 1.0460 / Hood: 1.0619+N
Operating pressure PS (bar-g)	0,1 - 4
Operating temperature TS (°C)	350
allowable differential pressure $\Delta PMX$ (bar):	4
for controller:	R4-P

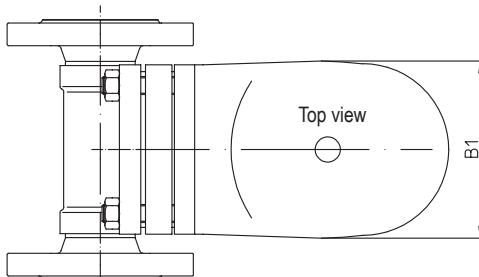
EN-JS1049 on request.

Types of connection

Flanges ....1	PN40 acc. to DIN 2501
---------------	-----------------------

Other types of connection on request.

For ANSI versions refer to data sheet CONA®S-ANSI



Dimensions and Weights		Types of connection				
		Flanges				
Nominal diameter	(mm)	40	50	65	80	100
L *	(mm)	230	230	290	310	350
H	(mm)	270	270	270	270	270
H1	(mm)	151	151	151	151	151
B	(mm)	307	307	307	307	307
B1	(mm)	157	157	157	157	157
S	(mm)	300	300	300	300	300
S1	(mm)	200	200	200	200	200
Weight approx.	(kg)	24,7	25,3	27,2	29,2	32,7

Standard-flange dimensions refer to page 21.

\* Face-to-face acc. to data sheet resp. customer request

### Parts

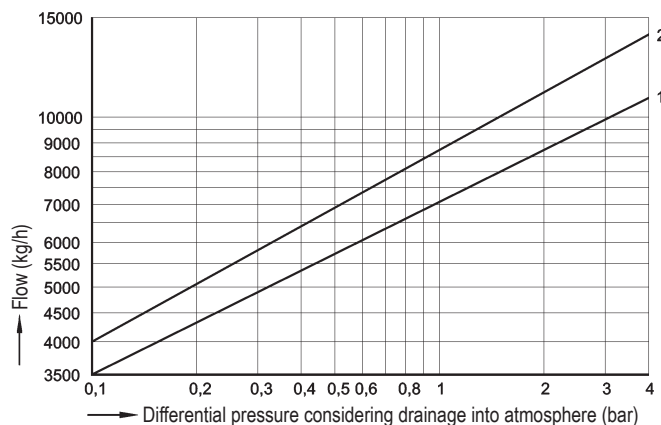
Pos.	Description	Fig. 45.633
1	Body	P250 GH, 1.0460
3	Seat	X8CrNiS18-9, 1.4305
4	Capsule *	X5CrNi18-10, 1.4301
5	Spring actuated clip *	X10CrNi18-8, 1.4310
16	Hood	GP240GH+N, 1.0619+N
17	Gasket *	Graphite (CrNi laminated with graphite)
24	Controller *	X5CrNi18-10, 1.4301 / bimetal TB102/85
27	Stud	21CrMoV 5-7, 1.7709
28	Hexagonal nut	21CrMoV 5-7, 1.7709
37	Intermediate flange	P250 GH, 1.0460
39	Baffle straightener	X14CrMoS17+QT, 1.4104+QT
46	Blow down valve, cpl. *	X8CrNiS18-9, 1.4305
49	Sealing ring *	X6CrNiTi18-10, 1.4541
50	Plug (M14x1,5) *	21CrMoV 5-7, 1.7709
51	Manual air vent valve *	X8CrNiS18-9, 1.4305

\* Spare part

Information / restriction of technical rules need to be observed!

Operating instructions can be ordered by phone +49 (0)5207 / 994-0 or fax +49 (0)5207 / 994-158 or -159.

### Capacity chart

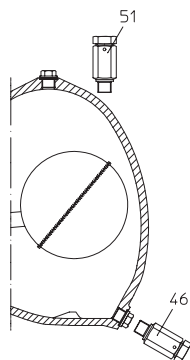


The capacity chart shows the maximum flow rates.

**Curve 1:**  
Maximum flow quantities of hot condensate.

**Curve 2:**  
Maximum flow quantities of cold condensate of about 20°C.

### Options



Ball float steam trap (Forged steel/Grey cast iron, Forged steel/Cast steel, Stainless steel)

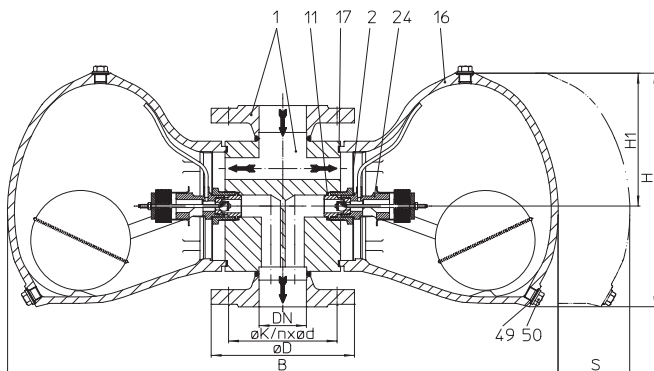


Fig. 639....1 with flanges - vertical installation

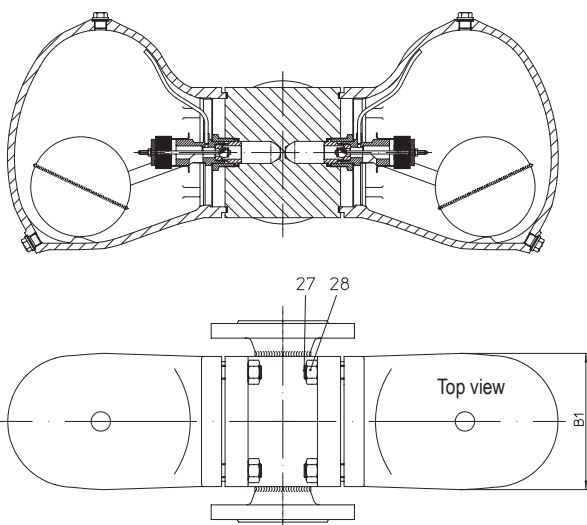


Fig. 639....1 with flanges - horizontal installation

The controller R4-P deviates in his construction from the shown controller on this side. Refer to Fig. 633 (page 10).

- Ball float steam trap with level control for the condensate-discharge from all kinds of steam systems for large condensate flowrates
- Discharge of great condensate quantities even at low differential pressure
- Rapid system start-up due to thermostatic control element
- Standard installation position: - vertical
- Optional installation position: - horizontal
- Inside strainer
- Body with flanged hood
- Non return protection
- The controller maybe changed without disturbing the pipe work
- On-site change of the installation position is possible according to the operating instructions; with an existing external vent there are modifies bypass parts needed due to the required installation position - please inquire.
- Options: - External vent cpl. for venting of high quantities of air during start-up and operation (standard with controller R2-S, R4-S and R4-P)

Operating limits

<b>Fig. 42.639</b>	<b>PN16</b> <b>Body: 1.0460 / Hood: EN-JL1040</b>
Operating pressure PS (bar-g)	13
Operating temperature TS (°C)	300

allowable differential pressure ΔPMX (bar):	2	4	8	13
for controller:	R2-S	R4-S	R8-S	R13-S

<b>Fig. 45.639</b>	<b>PN40</b> <b>Body: 1.0460 / Hood: 1.0619+N</b>	
Operating pressure PS (bar-g)	32	21
Operating temperature TS (°C)	250	400

allowable differential pressure ΔPMX (bar):	2	4	8	13	22	32
for controller:	R2-S	R4-S	R8-S	R13-S	R22	R32

<b>Fig. 55.639</b>	<b>PN40</b> <b>Body: 1.4541 / Hood: 1.4308</b>	
Operating pressure PS (bar-g)	32	28
Operating temperature TS (°C)	250	300

allowable differential pressure ΔPMX (bar):	2	4	8	13	22	32
for controller:	R2-S	R4-S	R8-S	R13-S	R22	R32

Types of connection

Flanges ....1	PN16 / PN40 acc. to DIN 2501
---------------	------------------------------

Other types of connection on request.

For ANSI versions refer to data sheet CONA®S-ANSI

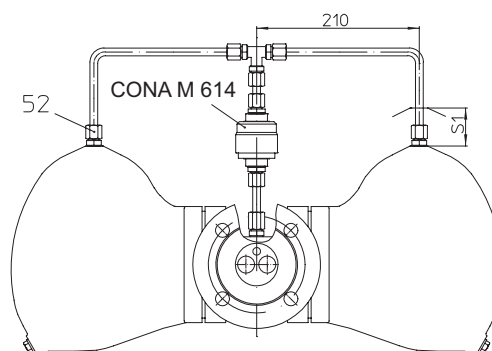


Fig. 639....1 with flanges - horizontal installation and external vent kpl.

Dimensions and Weights		Types of connection			
		Flanges			
Nominal diameter	(mm) (inch)	50 2	65 2 1/2	80 3	100 4
L*	(mm)	230	290	310	350
H	(mm)	270	270	270	270
H1	(mm)	151	151	151	151
B	(mm)	634	634	634	634
B1	(mm)	157	157	157	157
S	(mm)	300	300	300	300
S1	(mm)	200	200	200	200
Weight PN16	(kg)	44,7	46,2	27,7	50,5
Weight PN40	(kg)	26	28,3	50,5	55

Standard-flange dimensions refer to page 21.

\* Face-to-face acc. to data sheet resp. customer request

### Parts

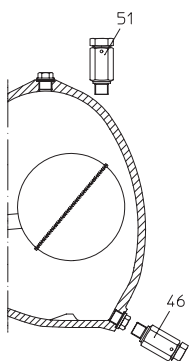
Pos.	Description	Fig. 42.639	Fig. 45.639	Fig. 55.639
1	Body	P250 GH, 1.0460		X6CrNiTi18-10, 1.4541
2	Strainer	X5CrNi18-10, 1.4301		
11	Sealing ring *	R-Cu99		
16	Hood	EN-GJL-250, EN-JL1040	GP240GH+N, 1.0619+N	GX5CrNi19-10, 1.4308
17	Gasket	Graphite (CrNi laminated with graphite)		
24	Controller *	X5CrNi18-10, 1.4301 / bimetal TB102/85		
27	Stud	C35E, 1.1181	21CrMoV 5-7, 1.7709	X6CrNiTi18-10, 1.4541
28	Hexagonal nut	C35E, 1.1181	21CrMoV 5-7, 1.7709	X6CrNiTi18-10, 1.4541
46	Blow down valve, cpl. *	X8CrNiS18-9, 1.4305		
49	Sealing ring *	R-Cu99		X6CrNiTi18-10, 1.4541
50	Plug (M14x1,5) *	21CrMoV 5-7, 1.7709		X6CrNiTi18-10, 1.4541
51	Manual air vent valve *	X8CrNiS18-9, 1.4305		
52	Union for pressure compension line *	X8CrNiS18-9, 1.4305		

\* Spare part

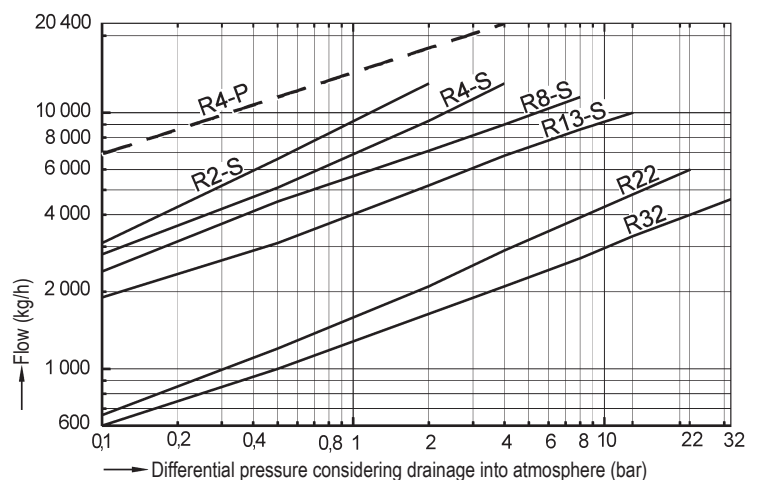
Information / restriction of technical rules need to be observed!

Operating instructions can be ordered by phone +49 (0)5207 / 994-0 or fax +49 (0)5207 / 994-158 or -159.

### Options (R8-S to R32)



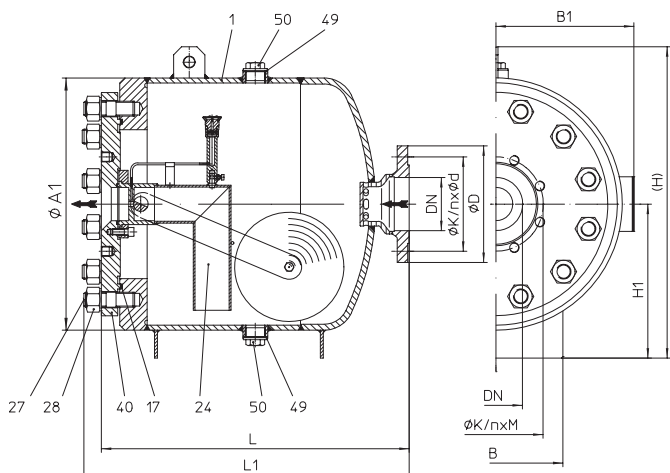
### Capacity chart



The capacity chart shows the maximum flow quantities of hot condensate for the different controllers and steam trap sizes

**Ball float steam trap (Steel)**

- Ball float steam trap with level control for the condensate-discharge from all kinds of steam systems
- Rapid system start-up and venting of air during operation due to thermostatic air venting capsule (only at Fig.637 necessary)
- Immediate discharge of hot boiling condensat
- Standard installation position: - horizontal
- Fig. 637: straight through (inlet from right or left)  
Fig. 638: Angle pattern design (inlet from the top)
- Capacity: 74 litres
- Drain plug
- Support points
- Simple exchange of controller.
- Options: - pre-assembled welding neck flanges to the inlet and outlet (standard on DN50)



**Operating limits**

Fig. 85.637 / 85.638	PN40 Body: P265GH / Cover: P355NH			
Operating pressure PS (bar-g)	40	29	25	22
Operating temperature TS (°C)	120	250	300	350
allowable differential pressure $\Delta PMX$ (bar):	4	14	23	30
for controller:	R4	R14	R23	R30

**Types of connection**

Flanges ....1	PN40 acc. to DIN 2501
---------------	-----------------------

Other types of connection on request (possibly note different operating limits).

For ANSI versions refer to data sheet CONA®S-ANSI

Fig. 637....1 with flanges -  
**Construction DN65-100**  
DN50: Connecting flange at the outlet (refer to page 15)

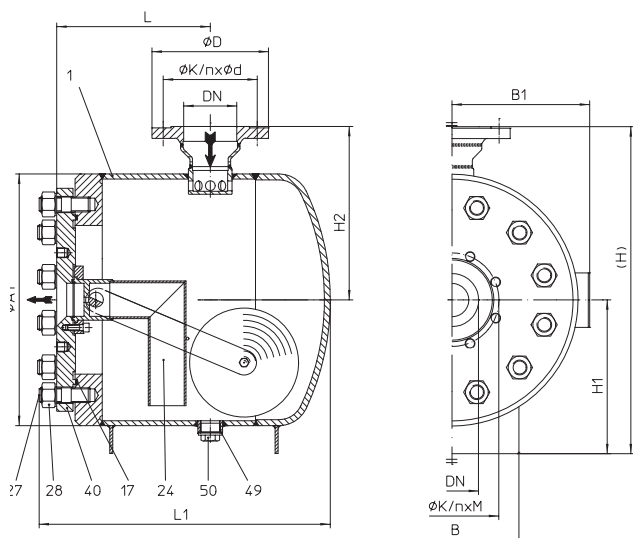


Fig. 638....1 Angle pattern design with flanges -  
**Construction DN65-100**  
DN50: Connecting flange at the outlet (refer to page 15)

Dimensions and Weights		Types of connection							
		Fig. 637 (Straightway)				Fig. 638 (Angle pattern design)			
Nominal diameter	(mm) (inch)	50 2	65 2 1/2	80 3	100 4	50 2	65 2 1/2	80 3	100 4
L	(mm)	750	620	620	620	445	310	310	310
L1	(mm)	656	656	656	656	588	588	588	588
H	(mm)	627	627	627	627	660	660	660	660
H1	(mm)	310	310	310	310	310	310	310	310
H2	(mm)	--	--	--	--	350	350	350	350
B	(mm)	270	270	270	270	270	270	270	270
B1	(mm)	280	280	280	280	280	280	280	280
Ø A1	(mm)	508	508	508	508	508	508	508	508
Ø K / n x M	(mm)	*	145 / 8 x M16	160 / 8 x M16	190 / 8 x M20	*	145 / 8 x M16	160 / 8 x M16	190 / 8 x M20
Ø K / n x d	(mm)	125 / 4 x 18	145 / 8 x 18	160 / 8 x 18	190 / 8 x 22	125 / 4 x 18	145 / 8 x 18	160 / 8 x 18	190 / 8 x 22
Weight approx.	(kg)	201	194	195	197	201	194	195	197

\* on DN50 connecting flange at the outlet standard (refer to bottom)

Face-to-face acc. to data sheet resp. customer request

### Parts

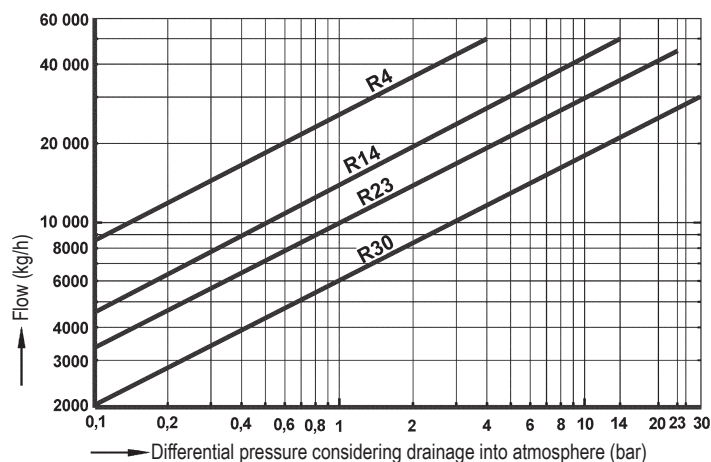
Pos.	Description	Fig. 85.637 / 85.638
1	Body	P265 GH, 1.0425
17	Gasket *	Graphite (CrNi laminated with graphite)
24	Controller *	X5CrNi18-10, 1.4301 / bimetal TB102/85
27	Stud	21CrMoV 5-7, 1.7709
28	Hexagonal nut	21CrMoV 5-7, 1.7709
40	Cover	P355NH, 1.0565
49	Gasket *	Graphite
50	Plug / Screw plug (G1 1/4") *	P250 GH, 1.0460
59	Gasket *	Graphite (CrNi laminated with graphite)

\* Spare part

Information / restriction of technical rules need to be observed!

Operating instructions can be ordered by phone +49 (0)5207 / 994-0 or fax +49 (0)5207 / 994-158 or -159.

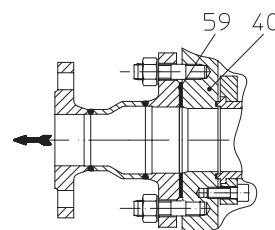
### Capacity chart



The capacity chart shows the maximum flow quantities of hot condensate for the different controllers and steam trap sizes

### Design of outlet connecting flange on DN50

Nominal diameter		Dimension and material for the studs and hexagon nuts for the connecting flange to the pipe flange (Pos. 40)	
(mm)	(inch)	Stud	Hexagonal nut
		DIN 939 - 1.7709	DIN 2510 - 1.7709
65	2 1/2	M16 x 55	NF M16 x 55
80	3	M16 x 55	NF M16 x 55
100	4	M20 x 55	NF M20 x 55



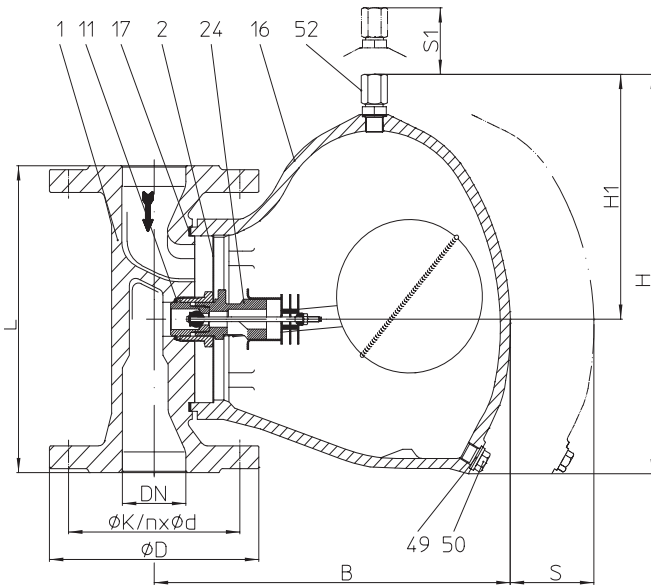
**Ball float steam trap (Grey cast iron, SG iron, Forged steel /Cast steel, Stainless steel)**


Fig. 630....1 with flanges - vertical installation

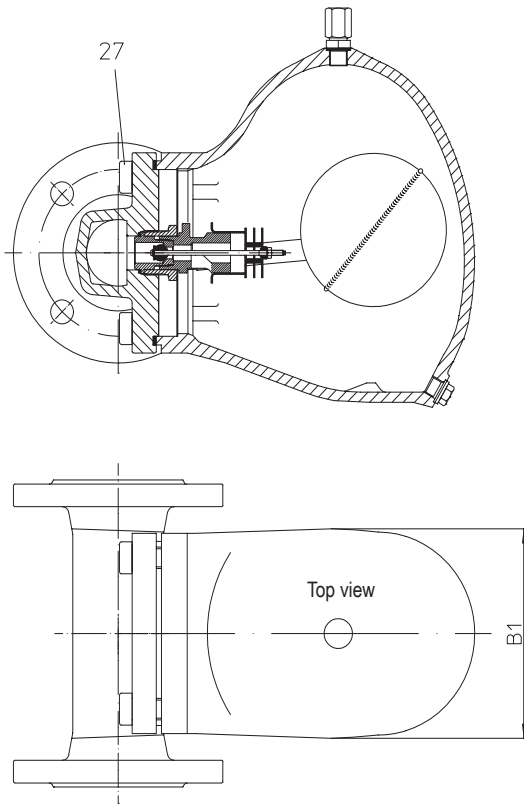
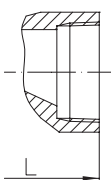
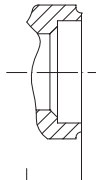
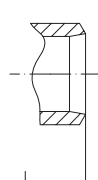


Fig. 630....1 with flanges - horizontal installation


 Fig. 630....2  
 with screwed sockets

 Fig. 630....3  
 with socket weld ends

 Fig. 630....4  
 with butt weld ends

- Ball float steam trap with level control for the condensate-discharge from compressed air and gas systems (acc. to PED 97/23/EG fluid group 2, other fluid groups on request)
- Standard installation position: - vertical
- Optional installation position: - horizontal with inlet from right or left (Please indicate when ordering).
- Inside strainer
- Body with flanged hood
- Non return protection
- Union (Pos. 52) for pressure compensation line
- The controller maybe changed without disturbing the pipe work
- On-site change of the installation position is possible according to the operating instructions
- Options: - Air vent - (Pos. 51) or blow down valve (Pos. 46), manual operated

**Operating limits**

Fig. 12.630	PN16 Body/Hood: EN-JL1040	
Operating pressure PS (bar-g)	12,8	9,6
Operating temperature TS (°C)	200	300

allowable differential pressure ΔPMX (bar):	2	4	8	13
for controller:	R2	R4	R8	R13

Fig. 25.630	PN40 Body/Hood: EN-JS1049	
Operating pressure PS (bar-g)	32	22
Operating temperature TS (°C)	250	350

allowable differential pressure ΔPMX (bar):	2	4	8	13	22	32
for controller:	R2	R4	R8	R13	R22	R32

Fig. 45.630	PN40 Body: 1.0460 / Hood: 1.0619+N	
Operating pressure PS (bar-g)	32	21
Operating temperature TS (°C)	250	400

allowable differential pressure ΔPMX (bar):	2	4	8	13	22	32
for controller:	R2	R4	R8	R13	R22	R32

Fig. 55.630	PN40 Body: 1.4541 / Hood:1.4308	
Operating pressure PS (bar-g)	32	28
Operating temperature TS (°C)	250	300

allowable differential pressure ΔPMX (bar):	2	4	8	13	22	32
for controller:	R2	R4	R8	R13	R22	R32

**Types of connection**

Flanges ....1	PN16 / PN40 acc. to DIN 2501
Screwed sockets ....2	R- and NPT-thread acc. to DIN EN 10226-1
Socket weld ends ....3	acc. to DIN EN 12760
Butt weld ends ....4	acc. to DIN EN 12627

Other types of connection on request.

**For ANSI versions refer to data sheet CONA®S-ANSI**

Dimensions and Weights		Types of connection														
		Flanges					Screwed sockets <sup>1)</sup> Socket weld ends <sup>2)</sup>					Butt weld ends <sup>2)</sup>				
Nominal diameter	(mm) (inch)	15 1/2	20 3/4	25 1	40 1 1/2	50 2	15 1/2	20 3/4	25 1	40 1 1/2	50 <sup>1)</sup> 2 <sup>1)</sup>	15 1/2	20 3/4	25 1	40 1 1/2	50 2
L*	(mm)	150	150	160	230	230	150	150	160	210 <sup>3)</sup>	210	160	160	160	250	250
H	(mm)	188	188	213	296	296	188	188	213	296	296	188	188	213	296	296
H1	(mm)	111	111	128	177	177	111	111	128	177	177	111	111	128	177	177
B (EN-JS1049)	(mm)	214	214	255	280	280	214	214	255	280	--	-	--	--	--	--
B (steel)	(mm)	214	214	255	280	280	167	167	196	285	285	167	167	196	285	285
B1	(mm)	95	95	118	157	157	95	95	118	157	157	95	95	118	157	157
S	(mm)	180	180	200	300	300	180	180	200	300	300	180	180	200	300	300
S1	(mm)	150	150	180	200	200	150	150	180	200	200	150	150	180	200	200
Weight approx.	(kg)	7,9	8,1	10,9	24,7	25,3	7,3	7,3	8,5	20	20,5	6,9	7,9	9	21	22

Standard-flange dimensions refer to page 21. <sup>1)</sup> DN50 (2") not for EN-JL/JS  
<sup>2)</sup> not for EN-JL/JS  
<sup>3)</sup> EN-JS: L = 230 mm

\* Face-to-face acc. to data sheet resp. customer request

### Parts

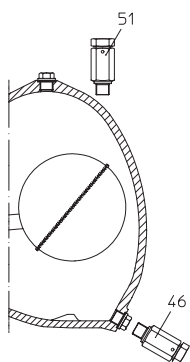
Pos.	Description	Fig. 12.630	Fig. 25.630	Fig. 45.630	Fig. 55.630	
1	Body	EN-GJL-250, EN-JL1040	EN-GJS-400-18U-LT, EN-JS1049	P250 GH, 1.0460	X6CrNiTi18-10, 1.4541	
2	Strainer	X5CrNi18-10, 1.4301				
11	Sealing ring *	R-Cu99				
16	Hood	EN-GJL-250, EN-JL1040	EN-GJS-400-18U-LT, EN-JS1049	GP240GH+N, 1.0619+N	GX5CrNi19-10, 1.4308	
17	Gasket *	Graphite (CrNi laminated with graphite)				
24	Controller *	TB 102 / 85 (corrosion resistant bimetal)				
27	Cheese head screw	X6CrNiTi18-10, 1.4541 / 8.8	21CrMoV 5-7, 1.7709	21CrMoV 5-7, 1.7709	X6CrNiTi18-10, 1.4541	
46	Blow down valve, cpl. *	X8CrNiS18-9, 1.4305				
49	Sealing ring *	R-Cu99				
50	Plug (M14x1,5) *	C35E, 1.1181	21CrMoV 5-7, 1.7709			X6CrNiTi18-10, 1.4541
51	Manual air vent valve *	X8CrNiS18-9, 1.4305			X14CrMoS17+QT, 1.4104+QT	
52	Union for pressure compension line *	X8CrNiS18-9, 1.4305			X14CrMoS17+QT, 1.4104+QT	

\* Spare part

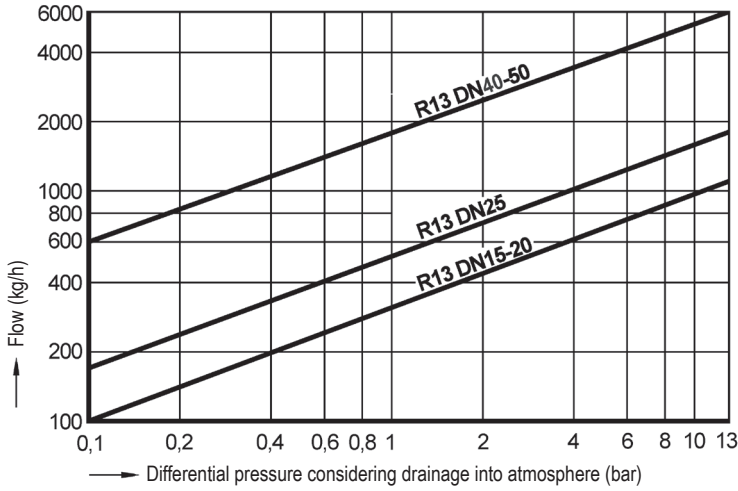
Information / restriction of technical rules need to be observed!

Operating instructions can be ordered by phone +49 (0)5207 / 994-0 or fax +49 (0)5207 / 994-158 or -159.

### Options

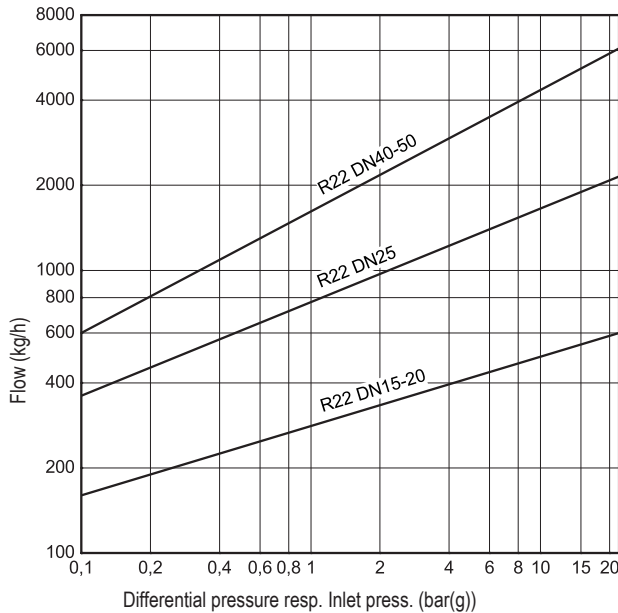


Capacity chart  
PN16  
Standard R13  
DN15 - DN50



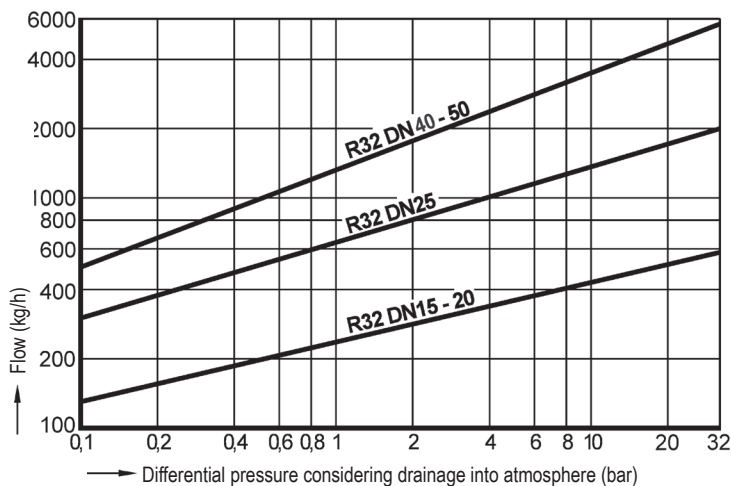
To determine the drainage quantity of cold water at about 20°C from compressed air and gas systems.

Capacity chart  
PN40  
Standard R22  
DN15 - DN50



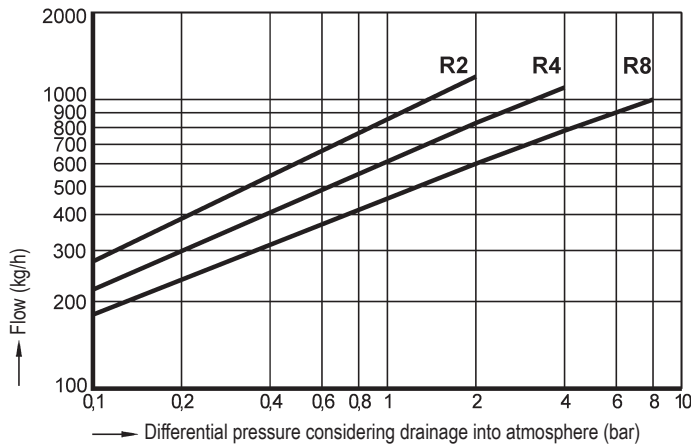
To determine the drainage quantity of cold water at about 20°C from compressed air and gas systems.

Capacity chart  
PN40  
Standard R32  
DN15 - DN50



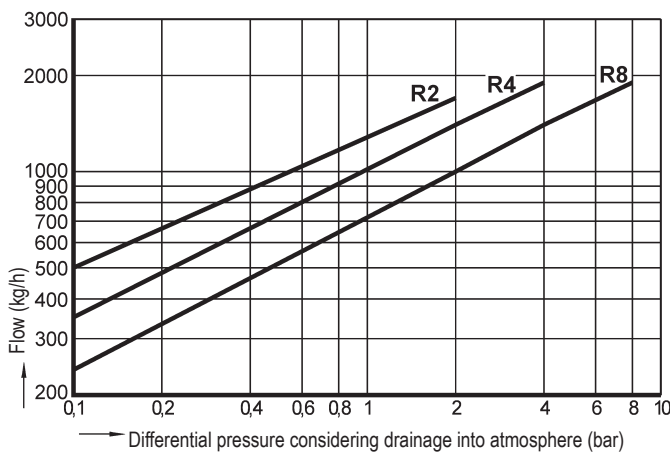
To determine the drainage quantity of cold water at about 20°C from compressed air and gas systems.

**Capacity chart**  
PN16 - PN40  
Special execut. R2, R4, R8  
DN 15 - DN 20



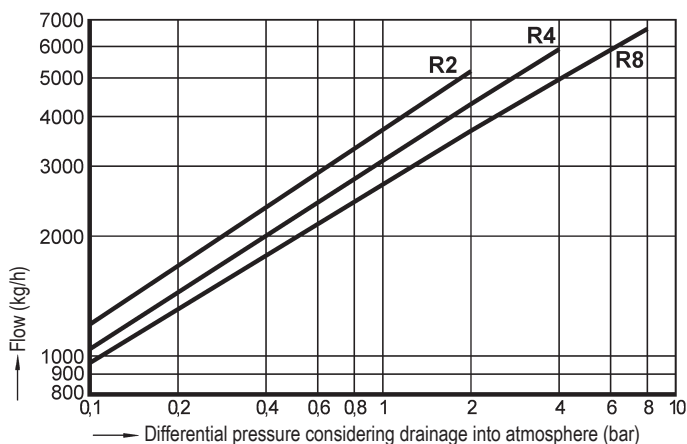
To determine the drainage quantity of cold water at about 20°C from compressed air and gas systems.

**Capacity chart**  
PN16 - PN40  
Special execut. R2, R4, R8  
DN 25



To determine the drainage quantity of cold water at about 20°C from compressed air and gas systems.

**Capacity chart**  
PN16 - PN40  
Special execut. R2, R4, R8  
DN 40 - DN 50



To determine the drainage quantity of cold water at about 20°C from compressed air and gas systems.

**Informations about pipe welding**
**Welding groove acc. to DIN 2559**

The material used for ARI valves with butt weld ends are:

1.0619+N	GP240GH+N acc. to DIN EN 10213-2
1.0460	P250GH acc. to DIN EN 10222-2
1.5415	16Mo3 acc. to DIN EN 10028
1.4541	X6CrNiTi18-10 acc. to DIN EN 10088
1.7335	13CrMo4-5 acc. to DIN EN 10028

Due to our experience, we recommend to apply an electric welding process.

Because of the different material compositions and wall thickness of the steam traps and the pipe gas welding shall not be applied. Quenching cracks and coarse grain structure may develop.

Steam traps with socket-weld ends shall only be welded by arc welding (welding process 111 acc. to DIN EN 24063).

If during the time of warranty others than the manufacturer or by the manufacturer authorized persons are interfering in the product and/or the setting, the right of claim for warranty will lapse!

**Integrated non return protection**

The integrated non return protection acts as a check valve (except BR633 and BR639 R4-P, R2-S, R4-S).

In case of parallel installed heat exchangers or heater batteries the non return protection prevents a shut down heat-exchanger from flooding with condensate from the downstream side and reverse heating up.

A check valve which otherwise has to be installed is not necessary.

**Installation with pressure compension line**

**Important:**  
The installation of a pressure compensation line for gas return is always recommended; especially if the ball float steam trap is installed horizontally.

**Selection criteria:**

- Steam pressure
- Back pressure
- Quantity of condensate
- Flow medium
- Nominal diameter / pressure
- Type of connection
- Material
- Place of service or kind of steam consumer

Other installation positions than standard ( vertical ) have to be indicated together with the information about the flow direction i.e. inlet from left or right

**Example for order data:**

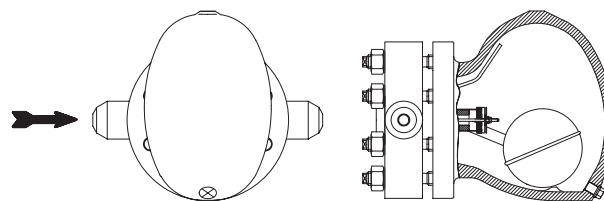
=> Ball float steam trap CONA® S,  
Fig. 630, PN40, DN50, 1.0460/1.0619+N, Controller R22, with flanges, Face-to-face dimension 230 mm

Dimensions in mm resp. inch
Weights in kg
1 bar $\hat{=}$ 10 <sup>5</sup> Pa $\hat{=}$ 0,1 MPa
Kvs in m <sup>3</sup> /h
1 bar $\hat{=}$ 14,5 psi
1 inch $\hat{=}$ 25,4 mm

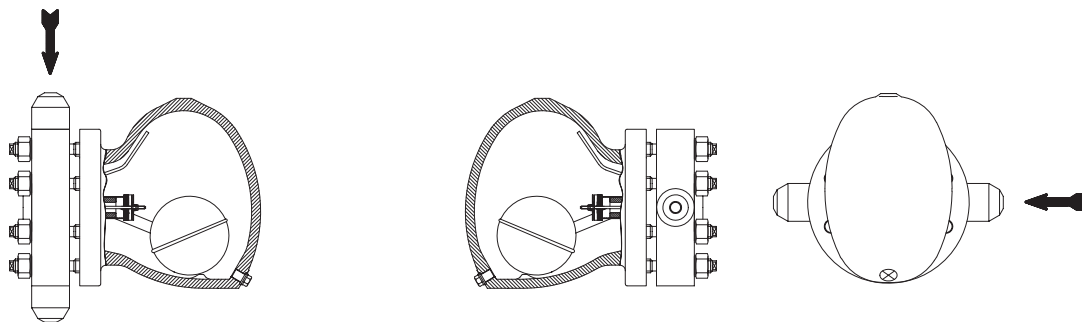
**Standard-flange dimensions**

Flanges according to DIN 2501

DN		(mm)	15	20	25	32	40	50	65	80	100
PN16	ØD	(mm)	95	105	115	140	150	165	185	200	220
PN16	ØK	(mm)	65	75	85	100	110	125	145	160	180
PN16	n x Ød	(mm)	4 x 14	4 x 14	4 x 14	4 x 18	4 x 18	4 x 18	4 x 18	8 x 18	8 x 18
PN25	ØD	(mm)	--	--	--	--	--	--	185	200	235
PN25	ØK	(mm)	--	--	--	--	--	--	145	160	190
PN25	n x Ød	(mm)	--	--	--	--	--	--	8 x 18	8 x 18	8 x 18
PN40	ØD	(mm)	95	105	115	140	150	165	185	200	235
PN40	ØK	(mm)	65	75	85	100	110	125	145	160	190
PN40	n x Ød	(mm)	4 x 14	4 x 14	4 x 14	4 x 18	4 x 18	4 x 18	8 x 18	8 x 18	8 x 22
PN63	ØD	(mm)	105	--	140	--	170	180	--	--	--
PN63	ØK	(mm)	75	--	100	--	125	135	--	--	--
PN63	n x Ød	(mm)	4 x 14	--	4 x 18	--	4 x 22	4 x 22	--	--	--
PN100	ØD	(mm)	105	--	140	--	170	195	--	--	--
PN100	ØK	(mm)	75	--	100	--	125	145	--	--	--
PN100	n x Ød	(mm)	4 x 14	--	4 x 18	--	4 x 22	4 x 26	--	--	--
PN160	ØD	(mm)	130	--	150	--	--	195	--	--	--
PN160	ØK	(mm)	75	--	100	--	--	4 x 26	--	--	--
PN160	n x Ød	(mm)	4 x 14	--	4 x 18	--	--	4 x 26	--	--	--

**Information about the different installation positions (shown at Fig. 631)**


Horizontal installation - inlet from the left side (ZL)



Vertical installation (standard)

Horizontal installation – inlet from the right side (ZR)

**Installation (see picture)**

The ball float steam traps can be installed either in vertical (standard) or horizontal position. In case of horizontal installation please indicate whether the inlet is from the left or right side.

The steam trap can also be converted on site to match the different installation positions. Please observe the appropriate operating manuals.

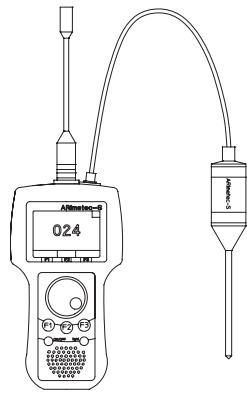
The steam trap must be fitted with the direction of flow as indicated by the arrow on the body.

A clearance of 300 mm for the removal of the hood shall be provided.

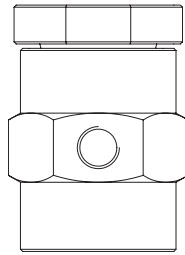
The steam trap shall preferably be installed at the lowest point of the system and the membrane capsule resp. the bleeding tube shall be installed in an upright position inside of the hood.

**For the modification of the installation position observe the operating manual.**

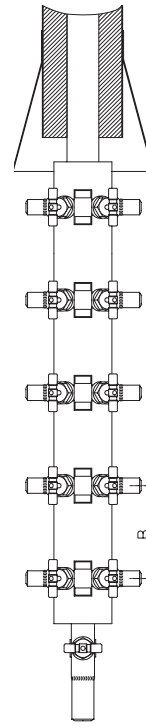
A modification of the installation position during the time of warranty shall be carried out by the AWH-Service or it shall be agreed between the customer and manufacturer.



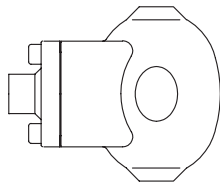
Multifunction tester ARImetec<sup>®</sup>-S



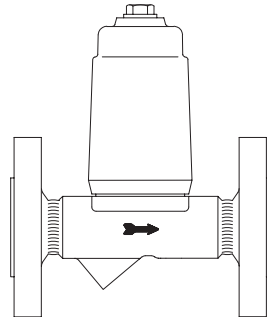
Vacuum breaker Fig. 655



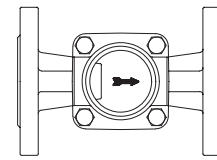
Condensate collection (B = 160), steam distribution (B = 120)  
CODI<sup>®</sup>S with gland packing Fig. 671/672;  
CODI<sup>®</sup>B with bellows seal, maintenance-free Fig. 675/676



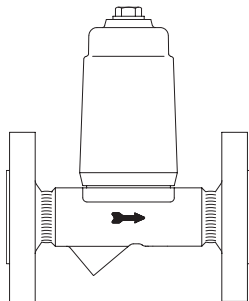
Automatic air vent for liquid systems  
Fig. 656



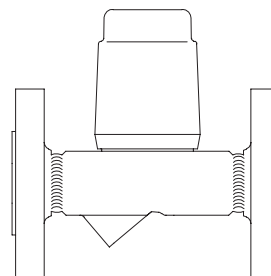
Condensate discharge temperature limiter  
Fig. 645/647



Flow indicator  
Fig. 660/661



Return temperature limiter Fig. 650



Liquid drainer Fig. 665

(Further informations about the accessories can be found in the appropriate data sheets.)